

**R. MYGUSHCHENKO, O. POTETENKO, A. GASIYK, E. KRUPA**

## **IMPROVEMENT OF THE WORKING PROCESS OF HYDROTURBINES AND ITS REGULATION SYSTEMS**

The paper provides the detail analysis of the causes of various types of the vortex motion of the turbulent flow in the inlet parts of the turbine and in the inter-blade channels of the runner. The causes of the appearance of large-scale vortex structures in the meridional sections of the spiral case of radial-axial hydraulic turbines with the heads of 400–500 m are shown. As a result of this phenomenon, in the section of the spiral case the flow is directed in the region of the walls to the runner. In the central part it is directed from the runner, i. e. the spiral case executing its functions of supplying the flow functions only with part of its section – the near-wall zone – where the vortex near-wall flow with increased velocity and energy losses enters to the channels of the runner. These conclusions in the work are argued by extensive experimental data. Energy losses in the spiral case reaches 3–5 % and a complex vortex structure, which enters to the runner, leads to a decrease of the energy characteristics. The flow inlet to the runner using nozzle devices located on the ring in front of the runner is considered in the paper. These nozzle devices increase the velocity by five or more times and provide low losses in the inlet (about 0,5 %) and almost uniform flow in front of the runner with a moment of quantity of motion, which provides an optimal operation of the hydraulic turbine. The improvement of the working flow and control systems is presented in this paper using new design solutions, for which more than ten patents of Ukraine for the invention were obtained. In particular, as a result of this study of the working processes of Francis-Deriaz hydraulic turbines, which allowed the use of blade turbines for the heads of more than 400–500 m up to 800–1000 m with high energy and cavitation characteristics with wide operating areas in terms of rates (powers) and heads, with an increase of 2–7 % average operating efficiency. The working process of a new type of diagonal-axial hydraulic turbine with a very wide operation range in terms of flow and pressure with a significantly increased average operating efficiency, increased operation reliability, which is illustrated by the predictive universal characteristic, is also considered. This characteristic allows the use of rotary-blade hydraulic turbines for heads up to 230–250 m. Therefore, the carried out improvement of the working process of hydraulic turbines and their control systems convincingly proves the advantage of the new scientific and technical solutions in comparison with previously used ones.

**Keywords:** high-head Francis turbine, runners, turbine inlet, energy losses, Francis-Deriaz turbine, regulation system.

**Р. П. МИГУЩЕНКО, О. В. ПОТЕТЕНКО, О. І. ГАСЮК, Є. С. КРУПА**

## **ВДОСКОНАЛЕННЯ РОБОЧОГО ПРОЦЕСУ ГІДРОТУРБІН ТА СИСТЕМ ЇХ РЕГУЛЮВАННЯ**

В роботі проведено детальний аналіз причин виникнення різних видів завихреності турбулентного потоку в підвідних органах гідротурбіни і в міжлопатевих каналах робочого колеса. Показано причини виникнення великомасштабних вихрових структур в меридіональних перетинах спіральних камер радіально-осьових гідротурбін на напори 400–500 м. Внаслідок цього явища в перерізі спіральної камери потік спрямований в області стінок до робочого колеса, а в центральній частині від робочого колеса, тобто спіральна камера виконуючи свою функцію підведення потоку функціонує лише частиною перетину – пристіночної зони, в якій завихрений пристінковий потік зі збільшеною швидкістю і втратами енергії надходить в канали робочого колеса. Ці висновки в роботі аргументовані чисельними експериментальними даними. Втрати енергії в спіральній камері досягають 3–5 % і складна вихрова структура, що надходить в робоче колесо приводить до зниження енергетичних показників. В роботі розглядається підвід потоку до робочого колеса за допомогою розташованих по кільцю перед робочим колесом соплових апаратів, що збільшують швидкість в п'ять і більше разів і забезпечують низькі втрати в підвідних органах (близько 0,5 %) практично рівномірний потік перед робочим колесом з моментом кількості руху, що забезпечує оптимальну роботу гідротурбіни. Удосконалення робочого процесу і систем регулювання представлено в цій роботі з використанням нових конструктивних рішень, на які отримані більш десяти патентів України на винахід. У тому числі в результаті дослідження робочих процесів радіально-діагональних гідротурбін, що дозволили застосовувати лопатеві турбіни на напори понад 400–500 м аж до 800–1000 м з високими енергокавітаційними показниками з широкими зонами експлуатації по витратах (потужностям) і напору, зі збільшенням на 2–7 % середньоексплуатаційним ККД. Розглянуто також робочий процес нового типу діагонально-осьової гідротурбіни з досить широким діапазоном експлуатації по витратах та напору з істотно підвищенням середньоексплуатаційним ККД, підвищеною надійністю експлуатації, що ілюструється прогноною універсальною характеристикою, що дозволяє застосувати поворотньо-лопатеві гідротурбіни на напори до 230–250 м. Таким чином, проведено вдосконалення робочого процесу гідротурбін і систем їх регулювання переконливо доводить перевагу нових науково-технічних рішень в порівнянні з раніше застосовуваними.

**Ключові слова:** високонапірна радіально-осьова гідротурбіна, робоче колесо, підвід гідротурбіни, втрати енергії, радіально-діагональна гідротурбіна, система регулювання.

**Р. П. МИГУЩЕНКО, О. В. ПОТЕТЕНКО, А. И. ГАСЮК, Е. С. КРУПА**

## **СОВЕРШЕНСТВОВАНИЕ РАБОЧЕГО ПРОЦЕССА ГИДРОТУРБИН И СИСТЕМ ИХ РЕГУЛИРОВАНИЯ**

В работе проведен подробный анализ причин возникновения различных видов завихренности турбулентного потока в подводящих органах гидротурбины и в межлопастных каналах рабочего колеса. Показаны причины возникновения крупномасштабных вихревых структур в меридиональных сечениях спиральных камер радиально-осевых гидротурбин на напоры 400–500 м. Вследствие этого явления в сечении спиральной камеры поток направлен в области стенок к рабочему колесу, а в центральной части от рабочего колеса, т. е. спиральная камера, выполняя свои функции подвода потока, функционирует лишь частью сечения – пристеночной зоны, в которой завихренный пристеночный поток с увеличенной скоростью и потерями энергии поступает в каналы рабочего колеса. Эти выводы в работе аргументированы обширными экспериментальными данными. Потери энергии в спиральной камере, достигающие 3–5 % и сложная вихревая структура, поступающая в рабочее колесо, приводит к снижению энергетических показателей. В работе рассматривается подвод потока к рабочему колесу с помощью расположенных по кольцу перед рабочим колесом сопловых аппаратов, увеличивающих скорость в пять и более раз и обеспечивающих низкие потери в подводящих органах (порядка 0,5 %) практически равномерный поток перед рабочим колесом с моментом количества движения, обеспечивающим оптимальную работу гидротурбины. Совершенствование рабочего процесса и систем регулирования представлено в настоящей работе с использованием новых конструктивных решений, на которые получены более десяти патентов Украины на изобретение. В том числе в результате исследования рабочих процессов радиально-диагональных гидротурбин,

© R. Migushchenko, O. Potetenko, A. Gasiyk, E. Krupa, 2019

позволивших применять лопастные турбины на напоры свыше 400–500 м вплоть до 800–1000 м с высокими энергокавитационными показателями с широкими зонами эксплуатации по расходам (мощностям) и напорам, с увеличенным на 2–7 % среднеэксплуатационным КПД. Рассмотрен также рабочий процесс нового типа диагонально-осевой гидротурбины с весьма широким диапазоном эксплуатации по расходам и напорам с существенно повешенным среднеэксплуатационным КПД, повышенной надёжностью эксплуатации, иллюстрируемой прогнозной универсальной характеристикой, позволяющей применить поворотно-лопастные гидротурбины на напоры до 230–250 м. Таким образом, проведенное совершенствование рабочего процесса гидротурбин и систем их регулирования убедительно доказывает преимущество новых научно-технических решений по сравнению с ранее применяемыми.

**Ключевые слова:** высоконапорная радиально-осевая гидротурбина, рабочее колесо, подвод гидротурбины, потери энергии, радиально-диагональная гидротурбина, система регулирования.

**Introduction.** One of the main indicators of the country's industrial development level is the amount of energy consumed per capita. These days, the main sources of electricity generation are organic fuels (gas, oil, coal), nuclear fuel and hydropower sources. At the same time, the need of organic fuels for the automotive transport, chemical and electrical industries is constantly increasing, while easily available deposits are running out of reserves.

New deposits have to be developed in difficult-to-reach regions of the globe (remote areas, ocean and offshore shelves), which leads to an increase in the expense and cost of one kilowatt-hour of generated electricity [1].

In the near future wind and solar power cannot completely replace traditional types of energy generation because of the low density of energy flows, for example:

- wind power less than 100 kW/m<sup>2</sup>;
- solar power less than 0,1 kW/m<sup>2</sup>.

For example, the following data are:

- during burning coal in large power plants equal 500 kW/m<sup>2</sup>;
- during using nuclear fuel equal 650 kW/m<sup>2</sup>.

In addition, the energy generation from solar panels and windmills depends on the weather conditions and daily time.

Powerful wind turbines emit infrasound vibrations during operation, so they must be located at a sufficient distance from human settlements.

Due to the depletion of available fossil fuels and the increasing demand for motor vehicles and chemicals, most experts are inclined to believe that in the future nuclear fuel will be the most promising to generate electricity from power plants. However, nuclear power plants are not desirable to be located in earthquake-prone areas.

It should be noted that the cost of one kilowatt-hour of produced electricity at a nuclear power plant is 1,5–3 times, and at a large hydropower plant is much cheaper than at a power plant using organic fuel.

The percentage of electricity generation at hydroelectric power plants in developed countries is 15–40 % of total generation.

However, large power units, that are equipped with steam turbines, thermal and nuclear power plants can't be operated in the mode of covering the so-called peak loads of daily control.

In world practice, hydroelectric units, which are equipped with hydraulic turbines and pump-turbines, are used for this purpose (see Fig. 1).

Generally, the reserves of potential water energy concentrated in front of the hydroelectric station dam can be seen as a kind of hydraulic battery that can rapidly convert through a hydraulic turbine, combined with an electric generator, hydropower in electrical energy.

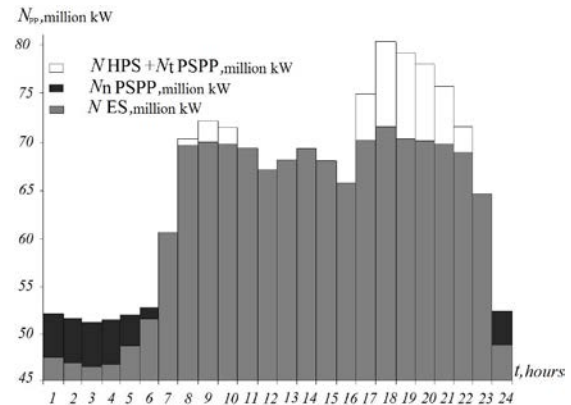

Fig. 1. The graph of the integrated power system daily load of the South Ukraine (data of the 1990)

It is known that the time to start or stop a hydraulic turbine is calculated in minutes. The start from the "synchronous compensator" mode to full power is calculated in units of seconds [2].

The so-called "group regulation of hydraulic turbines" is applied in the process of optimal units' control in an integrated power system, when the next stop or start of the hydroelectric unit operating units are transferred to the operation in close-to-optimal mode, i. e. with high efficiency. Sometimes this situation leads to cases when during the day the hydroelectric unit stops and starts at full capacity several times. Generally, hydroelectric units are practically not operated on a constant mode. The start and stop of hydraulic units, that are equipped with Francis or propeller (hard-bladed axial) hydraulic turbines, are associated with increased insecurity of flow on start-stop modes, which leads to increased vibration of the contracture, i. e. to reduce reliability and durability of operation. Turning-bladed hydraulic turbines have a significant advantage in this regard.

The features of the operation of the hydraulic turbine are considered, perspective trends of improvement are analyzed. They are oriented to increase the reliability and durability of the operation of hydraulic turbine equipment; improve energy-cavitation parameters of hydraulic turbines by improving the working flow, developing new design solutions, and improving the control system [1–3].

**1. The features of a vortex turbulent flow in the inlet units and in the inter-bladed channel of the runner of high-head hydraulic turbine (RO 400, RO 500).** The main roles of the inlet units of the hydraulic turbine (spiral case, channels between the stator columns and the wicket gate vanes) are:

1. To provide the uniform the flow inlet to the runner on the cylindrical surface in front of the runner with minimal energy losses.

2. To create a moment of quantity of the flow motion

in front of the runner that ensures the optimal operation of the hydraulic turbine [4].

From the law of conservation a moment of quantity of the motion, the difference of the moments of quantity of the fluid flow motion passing into a unit of time through the sections in front and behind the runner, taking into account the losses, is equal to the torque. This torque is transferred the flow to the runner and through the turbine shaft on the electric generator. Furthermore, the power transmitted through the shaft on the generator is equal to

$$N = M_{\text{torque shaft}} \cdot \omega,$$

where  $M_{\text{torque shaft}}$  – torque on the shaft of the hydraulic unit;  $\omega$  – the frequency of rotation of the rotor.

As we know, from this law follows Euler equation for a hydraulic turbine:

$$\frac{\eta_h g H}{\omega} = (rv_u)_1 - (rv_u)_2.$$

It is known that  $(rv_u)_2$  in the optimal mode of operation of the hydraulic turbine, which defines the so-called circulating energy losses, is close to zero. This makes an possibility for every specific turbine in the optimal operation mode to determine the value  $(rv_u)_1$ , that reduced to the unit mass flow of the moments of quantity of the fluid flow motion in front of the runner, which should be provided by the inlet units of the hydraulic turbine [5–8].

The value  $(rv_u)_1$  at the inlet of the runner for insuring the optimal operation of the hydraulic turbine (with  $(rv_u)_2 = 0$ ) can be get for the turbine with the diameter of the runner  $D_1 = 1$  m and the head  $H_1 = 1$  m, taking into account the eccentricity of the inlet section of the spiral case (the value  $(rv_u)_{\text{spir}}$  at the inlet of the spiral case), using the Euler equation for the hydraulic turbine and universal characteristics. While the nomenclature of large hydraulic turbines ("Hydraulic turbines for hydropower plants" 1984 OST 108.023.15-82) and analysis of the universal and "sizes" characteristics of the water passage are taken account.

Calculations show that  $(rv_u)_{\text{spir}} / (rv_u)_1 = 1,15$  (RO 45); 1,0 (RO 75); 0,59 (RO 230); 0,57 (RO 310); 0,55 (RO 400); 0,54 (RO 500).

The analysis showed that it is reasonable to design spiral chambers by law  $v_u r = \text{const}$  for hydraulic turbines RO 45 and RO 75, while for hydraulic turbines with higher head the application of this law leads to the increase of energy losses in the inlet units of the hydraulic turbines.

It is impossible to obtain  $(v_u r)_{\text{spir}} / (rv_u)_1 = 1$  for high-head hydraulic turbines, and especially for heads over 400–500 m. Because reducing the area of the input section of the spiral case almost in half or increasing the eccentricity of its location leads to either significant losses on friction in the spirals, or to significant increases in the

size of the hydroelectric unit in the plan. An attempt of using the channels between the stator columns (increasing their number) and the wicket gate inter-shoulder channels does not ensure the efficiency of the process of increasing a moment of quantity of the flow motion.

In addition, the higher the head of the hydraulic turbine, the movement of the fluid occurs in all channels including the spiral case and other flowing units with significantly increased velocity and when turning the flow with significantly increased centrifugal forces inertia. It is similar to the movement of liquid in the zone of sharp turn of the round pipeline in the form of a large-scale vortex structure (the so-called "vortex pair").

Comprehensive experimental research, conducted at the hydraulic turbine model stand of the Department of Hydraulic Machines named after G. F. Proskura of NTU "KhPI" (Fig. 2, 3), showed the existence of the "vortex pair" in the meridional section of the spiral case of the model hydraulic turbine RO 500-I-2b (Fig. 4) [9–11].

The structure of the flow in the meridional section of the spiral case shows that the section seems to be artificially broken into two zones: the near-wall zone in which the flow moves to the runner, and the central section zone in which the flow moves from the runner.

That is, a situation of reducing the section of the spiral case artificially creates due to the reverse influence of the runner, in which the flow leaves the blade system with close to zero circulation  $(rv_u)_2 \approx 0$  and centrifugal forces of flow inertia in the spiral case. So the appearance in the specific zone of the spiral case of the formation of an increased value  $(v_u r)$  of the flow moving to the runner. At the same time, energy losses on friction are significantly increased due to a significant increase in velocities in the near-wall zone of the spiral case.

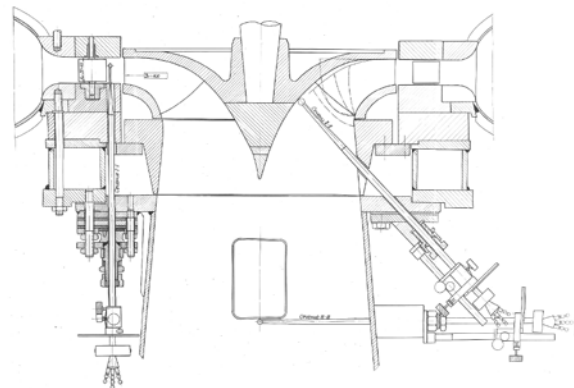

Fig. 2. The installation scheme of probes in measured sections of a model turbine

A fairly clear picture of the influence of small-scale near-wall moving to the runner and large-scale ("vortex pair") vortex structures which moves to the input section of the runner on the structure of the flow in front of the runner is presented on Fig. 5.

Analysis of the nature of the incident flow shows that even in optimal mode the blades profiles are flowed at different angles of attack and at different velocities, depending on their location in the height of the wicket gate's vanes (Fig. 6).

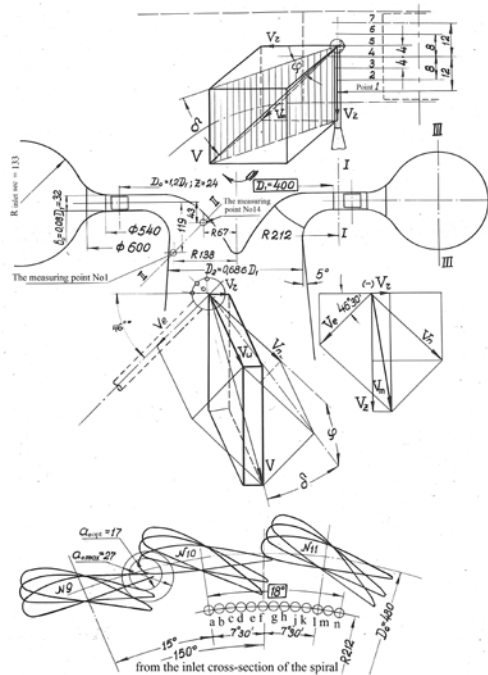

Fig. 3. The installation scheme of probes in measured sections of a model turbine

This leads to the fact that the circulation of velocity around the blade will also change accordingly, and from the outlet edges will slop not only the vortexes of the type "Carman's track" but also the inductive vortex formations with the character of the spiral vortex flow, caused by the change in circulation around the blades. Naturally, the presence of a gradient vorticity of the flow in the inter-blade channels of the runner, caused by a significant change in velocity in the direction from the pressure side to the side of discharge [10].

Due to the significantly higher values of absolute velocities on the vacuum side (discharging side) of the blade outside the border wall layer, compared to the working side, the intensity of the vortexes on this side in the near-wall zone exceeds intensity of vortexes on the

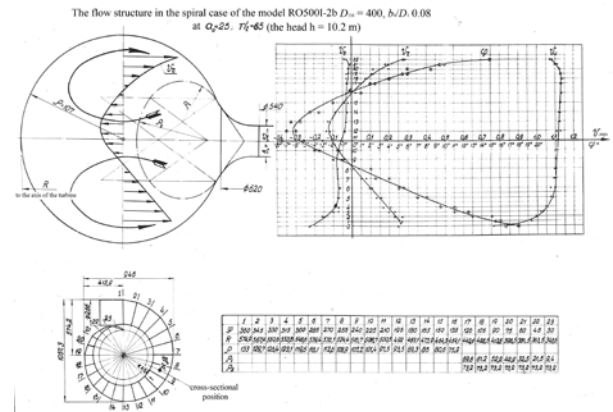

Fig. 4. The flow structure in the spiral case

pressure side of the blade.

As a result, on almost all modes of operation of the hydraulic turbine on the surface of the runner hub vortex lines "sloping" (bending) will descend to the surface of the cone fairing and further into the fluid flow, which goes into the draft tube, forming screw-shaped vortex (circulating) movement (Fig. 7).

If the circulation flows  $(v_u r)_2$  caused by the moment of quantity of fluid movement in the runner outlet, in the near-wall zone of the first cross section of the blade (near the hub) on the hydroturbine operation modes, which are different from the optimal, will be congruent in the direction of the rotations with inductive vortexes, which caused by the "slant" of vortex lines on the hub surface.

This will lead to the formation of powerful vortex "harnesses", which have a screw shape and rotate with a certain frequency around the axis rotation of the rotor of the hydraulic unit, in the draft tube. This is the main cause of low-frequency pressure pulsations of large amplitude, leading to vibrations of the walls, which limit the flow, and elements of the rotor of the hydraulic unit. All of this ultimately reduces the reliability and durability of the operation [12–14].

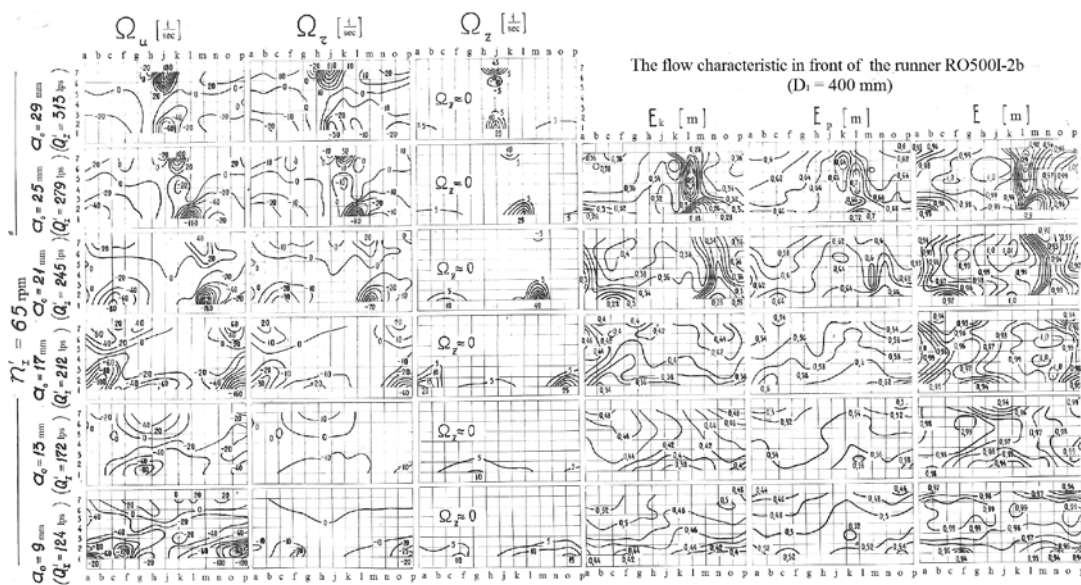

Fig. 5. The flow characteristics in front of runner

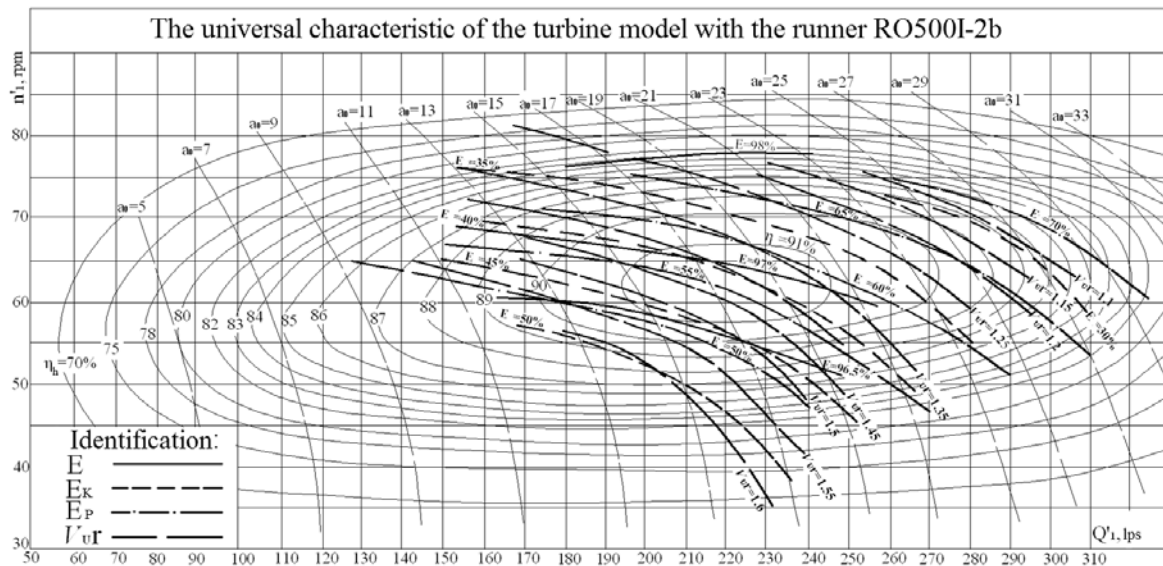

Fig. 6. The nature of the distribution of kinetic, potential and total energy in front of the runner as a percentage of the energy in the input section of the spiral case

On modes, which are different from optimal, in Francis hydraulic turbines by the law, which is close to the square parabola, depending on the rate change compared to optimal, increase circulating energy losses due to the part of the moment of quantity of movement that was not transferred to the runner. These losses in uncalculated mode prevail over the other losses. In Kaplan hydraulic turbines, circulation losses on uncalculated (non-optimal) modes are significantly lower. This provides a wider range of reliable operation of these hydraulic turbines at rates (power).

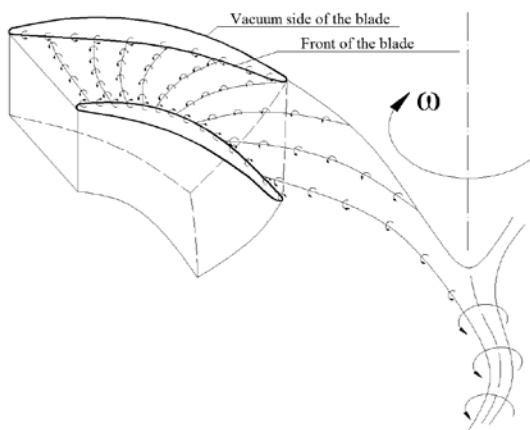

Fig. 7. Large-scale spiral-shaped vortex harnesses in a draft tube of a hydraulic turbine, which running off from the fairing of the runner

**2. The main ways of improving the hydraulic turbines operation and their control systems.** The main causes of large-scale vortex structures in the water passages of Francis hydraulic turbines, causing additional energy losses along with friction losses, volumetric and mechanical losses and reducing energy cavitation characteristics and characteristics of reliability, efficiency and durability of operation of hydro turbine equipment, were considered in the previous paragraph. This paragraph devoted to the main ways for reducing the unsteady and

swirling of the flow in the inlet units of the hydraulic turbine and in the inter-bladed channels of the runner to reduce the circulation of energy losses. And not only an improving of the water passage, but the issues of improving hydraulic turbine control systems are being considered in it.

(a) Distribution optimization of the maximum thickness of the blade from the peripheral to the central and hub profile.

To consider the description of the author's certificate for the invention of SU No. 1188359 "The Francis hydraulic turbine runner" received on July 1, 1985. Applicant: Production Association of Atomic Turbine Engineering "Kharkov Turbine Plant" [15].

The following is proposed as a constructive solution. The blades have the lowest maximum thickness of the average section (Fig. 8), the highest at the rims and in the current sections the thickness of  $h_i$ , determined from the equation:

$$h_i = h_1 \left[ k + (1-k) \left( \frac{y_i}{L/2} - 1 \right)^2 \right],$$

where  $h_1$  – the highest maximum thickness of blades;  $k$  – the coefficient, which is equal to 0,55–0,7;  $y_i$  – the height of the current section of blades;  $L$  – the height of the blades in the maximum thickness zone.

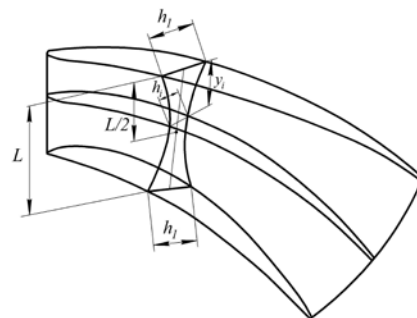

Fig. 8. The runner blade of the Francis turbine

There is a decrease in hydrodynamic losses and thus an increase in the efficiency of the hydraulic turbine during the operation of the runner of the Francis hydraulic turbine by thinning the blades in their middle sections, characterized by small bending moments. The thinning of the blades in the middle sections leads to a decrease in the metal-intensiveness of the runner. The greatest maximum thickness of the blades at the upper and lower rims avoid cracking in these areas, characterized by the greatest bending moments.

All hydraulic turbines, which produced by Leningrad Metal and Kharkiv turbine plants, are operated at hydroelectric power plants in Russia, Ukraine, and other countries. These hydrounits were manufactured in accordance with the Industrial Standard, an item of large hydraulic turbines with an invariable, constant maximum thickness at the hub, in the central part and at the rim of the runner of the radial-axis type.

Strength and cavitation limitations and restrictions are an obstacle to the use of the nomenclature runner, for example, RO 500/3508-V-80 No. 2269 HTP or RO 500/3502-B-80 No. 2515 HTP at the head of 600 m.

Applying of the abovementioned investigation with rational redistribution of maximum thickness (some reduction of it in the central part and increase near the hub and rim) can solve the problem of strength with using a hydraulic turbine, which should be designed for 500 m head, on the higher heads up to 600 m. Cavitation problems are solved by additional depth of the hydroelectric unit, i. e. increased support from the lower beef. This situation in the case of derivative high-head hydroelectric power plants with the underground type of the building of the hydroelectric power plants, made in rock excavation, practically does not significantly increase the cost of construction work, due to the additional depth of the hydroelectric unit [15].

Thus, to some extent, the problem to promote the using of Francis hydraulic turbines to higher heads can be solved.

(b) Using of nozzles as the supplying units that create the necessary moment of quantity of the flow motion in front of the runner with minimal energy loss. They are located on the ring in front of the runner and increase the velocity by five or more times.

Nozzle channels, which are evenly arranged in a circle and leading the flow to the runner, are represented in Fig. 9, 10, 11. The blades of the nozzle channels act as stator columns with rotary outlet edges instead of the wicket gate's vanes. At the same time, the spiral case is produced with spacious cross-sections, the velocity in which is reduced by 1,5–3 times. This provides a reduction in energy losses of friction in the spiral case and as a result the absence of the so-called "vortex pair".

An example of the using of nozzles with low energy losses of the flow that flowing into them are the nozzles of Pelton hydroturbines, nozzle blades units of steam and gas turbines. The flow, generated by the nozzles, is equal-velocity flow on the cylindrical surface in front of the runner with little or no "step" unevenness in the circular direction, with a high degree of accuracy. This creates favorable conditions for formation of laminar border layer

not only on the walls of nozzles, but also on most of the blades of the runner on the modes of operation close to optimal and correspondingly significant reduction in energy losses in the spiral inlet, and on the walls with laminar border layer [16–20].

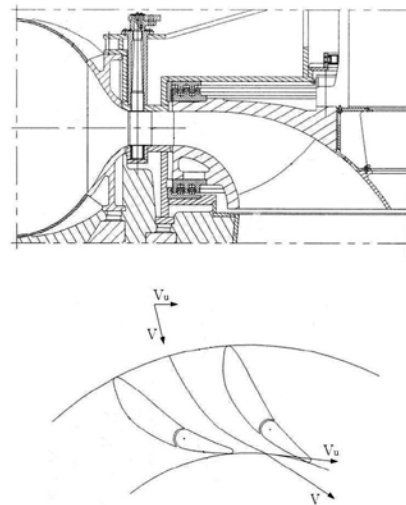

Fig. 9. The input units' construction of the high-head hydraulic turbine using nozzle devices

(c) The using of two-row (two-stage) and multi-row blade systems that provide a smoother system for the power (expense) regulation of a hydraulic turbine with a significant reduction in losses and expansion of the zone of efficient operation of hydraulic turbines [16].

The cross section of the high-head radial-diagonal hydraulic turbine is on the Fig. 10.

The high-pressure hydro turbine includes: a spiral case 1 with spacious meridional sections; nozzles with rotary severance edges 2, which forming the required moment of quantity of the flow motion in front of the runner and regulating the rate through the turbine; ring shutter 3, which also performs functions of an additional regulatory unit; a runner consisting of a hub 4, lower rim 5; the rigidly fixed blades of the radial-axis type 6 and the diagonal-type rotary blades between them; turn mechanism 8 and the draft tube. An additional wicket gate 9 with nozzle channels between the blades, creating an additional moment of quantity of the flow motion, which allows the most efficient operation of the hydro turbine on ultra-high 600–1000 m heads and most effectively use the same design in pump-turbines for hydro-accumulating power plants (HAPP) is in Fig. 11 [16].

Combinatorial dependence system, consisting of four regulatory elements: rotating outlet nozzle edges; moving upper surface of nozzles; rotary vanes of the intermediate wicket gate and unwrapped in the process of regulating the blades of a diagonal-type runner. A four-cell system of combinatorial dependence (Fig. 11) or three-cell system (Fig. 10) allows to expand the range of reliable operation of a hydraulic turbine with high energy cavitation indicators on consumption (capacity) and heads in 1,5–2 times. Moreover, it increases the unit capacity at the same size of the working runner, as well as increase the average operating efficiency by 2–5 %, more effectively use in working at peak daily regulation.

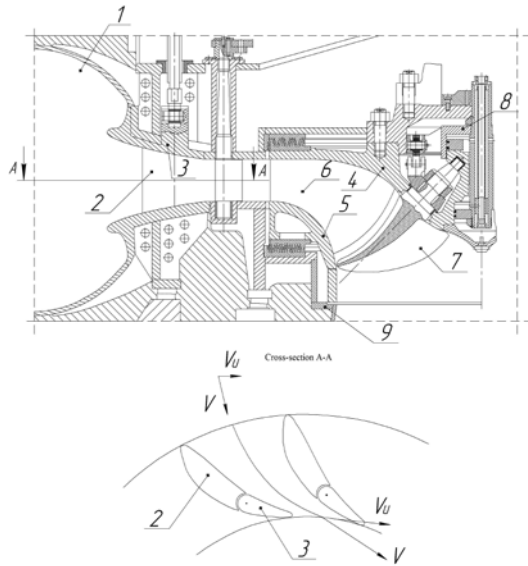

Fig. 10. The high-head radial-diagonal hydraulic turbine

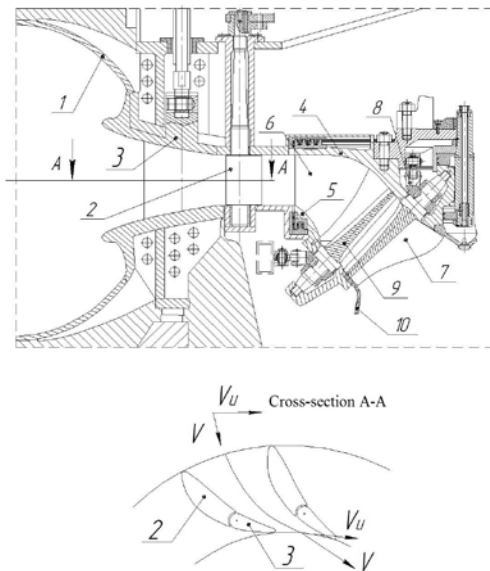

Fig. 11. The high-head radial-diagonal hydraulic turbine

The above benefits are illustrated in Fig. 12–14.

In constructing the universal characteristics of ROD 600 and ROD 700, the combinatorial dependence of the hydraulic turbine control system is taken into account in each mode of operation, providing the optimal ratio between  $H^{(RO)}$  and  $H^{(D)}$  given that  $H^{(RO)} + H^{(D)} = H^{(ROD)} = 1$  m and the optimal value  $n_1^{(ROD)}$  providing a minimum of energy loss, defined as:

$$h^{(ROD)} = \zeta^{(ROD)} H^{(ROD)} = h^{(RO)} + h^{(D)} = \zeta^{(RO)} H^{(RO)} + \zeta^{(D)} H^{(D)} = (1 - \eta_h^{(ROD)}) H^{(ROD)} = (1 - \eta_h^{(RO)}) H^{(RO)} + (1 - \eta_h^{(D)}) H^{(D)},$$

where  $h^{(ROD)}$ ,  $h^{(RO)}$ ,  $h^{(D)}$  – the head losses in the corresponding units of the water passage;  $\zeta^{(ROD)}$ ,  $\zeta^{(RO)}$ ,  $\zeta^{(D)}$  – the losses coefficients:  $\zeta = h/H$ ;  $\eta^{(ROD)}$ ,  $\eta^{(RO)}$ ,  $\eta^{(D)}$  – the efficiency coefficients.

The rate through the radial-diagonal hydraulic turbine:

$$Q^{(ROD)} = Q^{(RO)} = Q^{(D)}.$$

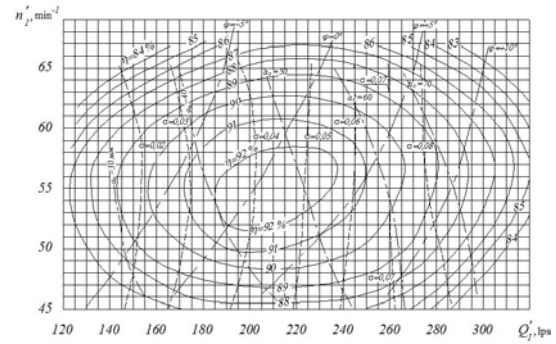

Fig. 12. The predictive universal characteristic of the hydraulic turbine ROD 600;  $D_1^{(D)} = 0,73$  m

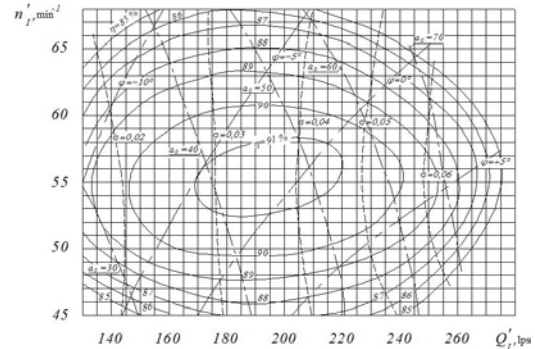

Fig. 13. The predictive universal characteristic of the hydraulic turbine ROD 700;  $D_1^{(D)} = 0,74$  m

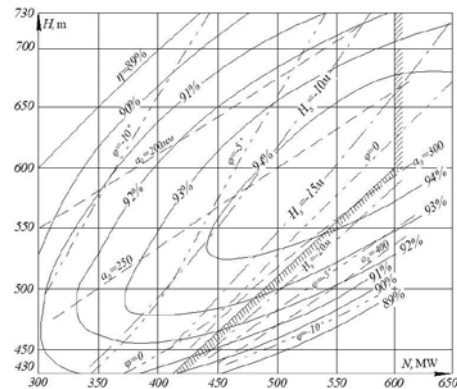

Fig. 14. The operational characteristic of the radial-diagonal hydraulic turbine ROD 600-V-450;  $N = 600$  MW,  $n = 300$  min<sup>-1</sup>,  $D_1 = 4,5$  m

The coefficient of the hydraulic losses in the radial-diagonal hydraulic turbine is determined as [19]:

$$\begin{aligned} \zeta^{(ROD)} &= \frac{h^{(ROD)}}{H^{(ROD)}} = \frac{1}{H^{(ROD)}} (\zeta^{(RO)} H^{(RO)} + \zeta^{(D)} H^{(D)}) = \\ &= \zeta^{(RO)} \frac{H^{(RO)}}{H^{(ROD)}} + \zeta^{(D)} \frac{H^{(D)}}{H^{(ROD)}} = (1 - \eta_h^{(RO)}) \frac{H^{(RO)}}{H^{(ROD)}} + \\ &\quad + (1 - \eta_h^{(D)}) \frac{H^{(D)}}{H^{(ROD)}}. \end{aligned}$$

The hydraulic efficiency of the radial-diagonal hydraulic turbine is, accordingly, equal to [11]:

$$\eta_h^{(ROD)} = (1 - \zeta^{(ROD)}) = \frac{1}{H^{(ROD)}} (\eta_h^{(RO)} H^{(RO)} + \eta_h^{(D)} H^{(D)}).$$

On the basis of the above formulas, the predictive universal characteristics of ROD 600 and ROD 700 for the diameter of the runner of the ROD  $D_1 = 1$  m (for  $D_1 = 1$  m) and head of  $H^{(ROD)}$  are built, i. e. in the system of coordinates and  $n'_i = \frac{nD_1}{\sqrt{H}}$  and  $Q'_i = \frac{Q}{D_1^2 \sqrt{H}}$  (at  $D_1^{(ROD)} = D_1^{(RO)} = 1$  m,  $H^{(ROD)} = 1$  m).

The constructive performance of a high-head diagonal-axis rotary-bladed hydraulic turbine at heads of 100–250 m and the predictive universal characteristic of this turbine at the head of 230 m are presented on the Fig. 15, 16 (PLDO 230) [19].

As known, axial rotary-bladed hydraulic turbines are used on hydropower plants at heads up to 80–100 m. They have a number of significant advantages compared to propeller (hard-bladed) and radial-axial hydraulic turbines applying to heads up to 80–100 m [16].

At the heads over 80–100 m axial-type Kaplan hydraulic turbines are not used, because at the head of 80 m Kaplan hydraulic turbine has the size of a hub, which places the rotary mechanism of eight blades is  $d_{hub} = 0,64D_1$  (64 % of the diameter of the runner). Transition to higher heads will cause of increase in the hub ratio. For the heads over 170 m can be used Kaplan hydraulic turbines of diagonal type, which as a disadvantage a much greater negative value of  $H_s$  – the depth of the unit in relation to the water level in the lower beef. For riverbed dam hydropower plants, this is a significant drawback leading to an increase in the volume of construction work.

Francis and especially propeller hydraulic turbines in comparison with Kaplan have a narrower range of power regulation (rate changes) from the conditions of efficiency and reliability of operation.

It should be noted that hydroelectric units most reliably and efficiently (with high energy cavitation characteristics) protect the electricity system from the so-called "frequency collapse" working mainly on peak loads

of daily regulation including the so-called "group regulation" system, which sometimes requires multiple launches and stops of the hydroelectric unit during the day.

At start of the hydraulic unit and at its emergence stop, which is connected with a disconnection from the electrical network, and for avoiding the acceleration of the non-rotation of the non-rotor unit, there are situations when the inlet edges of Francis and especially propeller hydraulic turbines flowing with large attack angles of up to 90 degrees with a wide detachable zone on the vacuum side of blade. This situation leads to undesirable large pressure pulsations and vibration of the walls and rotor of the hydraulic unit. In addition, Kaplan hydraulic turbines have undeniable advantages, such as minimizing circulating energy losses on operating modes different from optimal, allowing for a significant expansion of the unit operation zone by rate (power) and head with high energy and cavitation characteristics.

The diagonal-axis-type rotary-bladed hydraulic turbine, which presented in the Fig. 16 with the universal characteristic, is virtually devoid of the aforementioned flaws of hard-bladed hydraulic turbines and can be applied to pressures up to 230–250 m. The same positive properties have previously considered hydraulic turbines of radial-diagonal type with the possibility of their use at heads from 100 m to 800–1000 m with high operational (energy-cavitation and reliability) characteristics.

**Conclusions: 1.** Comprehensive study of the vortex structure of the turbulent flow of viscous fluid in the inlet units of high-head Francis hydraulic turbines RO 400 and RO 500 and in the inter-bladed channels of runner. The analysis of the causes of increased hydraulic energy losses has allowed to solve the problem of improving the working flow, improving operational energy cavitation characteristics, expanding the zone of high-efficiency and reliable work on rate (power) and heads, significantly improve the average efficiency, reliability and durability of the hydroelectric unit.

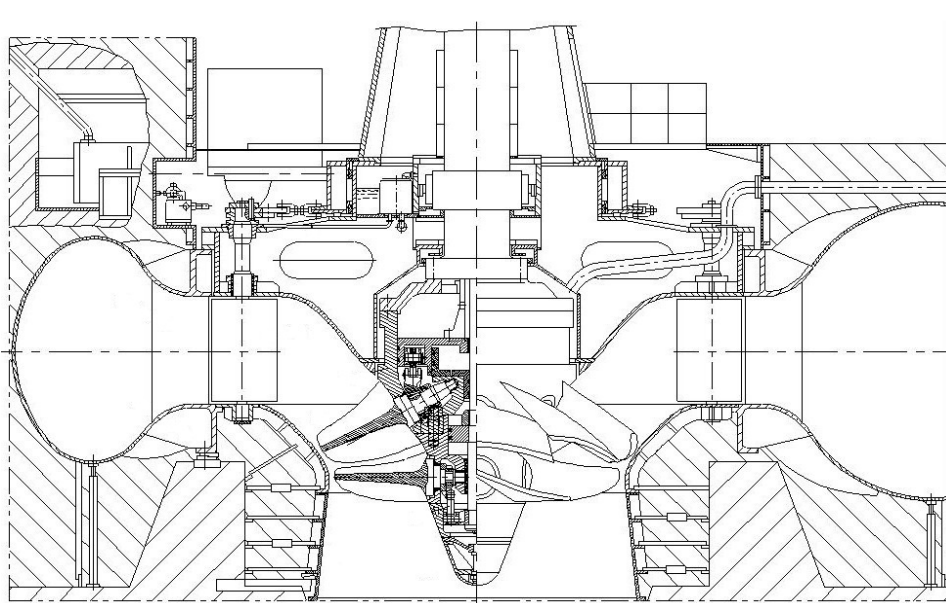

Fig. 15. The high-head Kaplan turbine



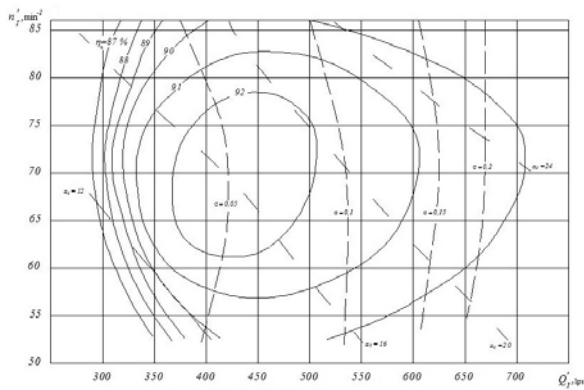

Fig. 16. The universal characteristic of a rotary-blade diagonal-axial hydraulic turbine PLDO 230

2. Scientific and technological developments, including new design solutions, improved working flow and regulatory (management) systems have made it possible to scientifically substantiate and propose for the first time in world practice high-performance hydraulic turbines on ultra-high heads up to 800–1000 m of radial-diagonal type and on increased heads of diagonal-axis type.

3. The using of radial-diagonal and diagonal-axis type of two- to four-element system of combinatorial dependence in the regulatory system for multi-stage blades of hydraulic turbines can improve reliability and efficiency of operation of the hydraulic turbines and pump-turbines (for GAPP) in a wide range of heads and powers.

#### References

1. Линник А. В., Хаитов В. Д. Современный уровень и основные направления развития гидротурбостроения в Украине. *Проблемы машиностроения*. 2010. Т. 13, № 1. С. 11–18.
2. Веремеенко И. С. Полвека поиска и созидания – итоги и перспективы развития отечественного гидротурбостроения. *Проблемы машиностроения*. 2003. Т. 6, № 2. С. 4–25.
3. Ландау Ю. А. Основные тенденции развития гидроэнергетики Украины. *Научные работы*. Харьков. 2014. Т. 53, вып. 40. С. 82–86.
4. Сухоребрый П. Н. Расчет спиральных камер радиально-осевых обратимых гидромашин. *Bulletin of the National Technical University "KhPI". Series: Hydraulic machines and hydraulic units*. Kharkiv: NTU "KhPI", 2001. Iss. 129, part 1.1. P. 79–89.
5. Nicolet C., Alligne S., Kawkabani B. Unstable operation of Francis Pump-Turbine at runaway: Rigid and elastic water column oscillation modes. *Journal of Fluid Machinery and Systems*. 2009. Vol. 2, no. 4. P. 324–333.
6. Топаж Г. И. *Лопастные гидромашини и гидродинамические передачи. Основы рабочего процесса гидротурбин*. Санкт-Петербург: Изд-во Политехн. Университет, 2011. 154 с.
7. Русанов А. В., Линник А. В., Сухоребрый П. Н., Хорев О. Н., Рябов А. В. Математическое моделирование течения жидкости и анализ характеристик потока в подводе гидротурбины ПЛ20 Кременчугской ГЭС. *Вісник Нац. техн. ун-та «ХПИ». Сер.: Енергетичні і теплотехнічні процеси і устаткування*. Харків: НТУ «ХПІ». 2014. № 1 (1044). С. 41–48.
8. Brekke H. *Hydraulic Turbines Design, Erection and Operation*. Endringsdato: Norway, 2000. 317 p.
9. Русанов А. В., Гнесін В. І. *Науково-технічні основи моделювання і проектування проточних частин енергетичних турбоустановок*. Харків: ПМаш, 2019. 386 с.
10. Потетенко О. В., Крупа Е. С. Комплексные экспериментальные исследования турбулентной структуры потока в проточной части высоконапорной радиально-осевой гидротурбины. *Bulletin of the National Technical University "KhPI". Series:*

*Hydraulic machines and hydraulic units*. Kharkiv: NTU "KhPI". 2016. No. 20 (1192). P. 33–40.

11. Линник А. В., Рябов А. В. Экспериментальный стенд ПАО «Турбоатом» для физического моделирования гидродинамических процессов в проточных частях моделей поворотных лопастных гидротурбин. *Проблемы машиностроения*. 2014. Т. 14, № 3. С. 11–18.
12. Rusanov A. Designing and updating the flow part of axial and radial-axial turbines through mathematical modeling. *Central European Journal of engineering*. 2015. Vol. 5. P. 399–410.
13. Masami Harano, Kiyohito Tani, Nomoto Satoru. Practical application of high-performance Francis-turbine runner fitted with splitter blades at Ontake and Shikurobegawa No. 3 power station of the Kansai electric power Co., inc. *Hitachi Review*. 2006. Vol. 55, № 3. P. 109–113.
14. Миронов К. А. Проектирование рабочих колес радиально-осевой высоконапорной гидротурбины на параметры ГЭС Каменг. *Вестник Нац. техн. ун-та «ХПИ»: сб. науч. тр. Темат. вып.: Технологии в машиностроении*. Харьков: НТУ «ХПИ». 2010. № 24. С. 69–76.
15. Фридман Л. И., Веремеенко И. С., Устьяев А. Д., Потетенко О. В. А. с. 1188359, СССР. *Рабочее колесо радиально-осевой гидротурбины*. 1985.
16. Потетенко О. В., Дранковский В. Э., Крупа Е. С., Вахрушева О. С. Совершенствование рабочих процессов гидротурбин с применением новых конструктивных решений для различных диапазонов напоров. *Вісник Нац. техн. ун-та «ХПИ». Сер.: Енергетичні і теплотехнічні процеси і устаткування*. Харків: НТУ «ХПІ». 2014. № 1 (1044). С. 49–57.
17. Сокол Е. И., Ищенко Г. И., Черкасский А. Ю., Ищенко М. Г., Линник А. В. Технологическое обеспечение изготовления гидравлической турбины для Днестровской ГАЭС. *Вісник Нац. техн. ун-та «ХПИ». Сер.: Технології в машинобудуванні*. Харків: НТУ «ХПІ». 2017. № 26 (1248). С. 5–13.
18. Субботин В. Г., Левченко Е. В., Ефименко В. Н. Оборудование ОАО «Турбоатом» для гидроэлектростанций Украины: модернизация, реабилитация и перспективы создания новых типов. *Гидроэнергетика Украины*. 2009. № 2. С. 33–43.
19. Потетенко О. В., Крупа Е. С., Дранковский В. Э., Резвая К. С. Особенности рабочего процесса новых типов горизонтальных прямоточных и вертикальных радиально-осевых гидротурбин на высокие напоры. *Вісник Національного університету водного господарства та природокористування*. Ровно, 2015. Вип. 3 (71): Частина I. Технічні науки. С. 281–285.
20. Робук Н. Н., Мелавцов А. А., Фридман Л. И., Остащенко А. В., Мишев Ю. Н., Савин В. Н., Потетенко О. В., Герман С. И. А. с. 206422, СССР. *Рабочее колесо радиально-осевой гидротурбины*. 1967.

#### References (transliterated)

1. Linnik A. V., Khaïtov V. D. Sovremennyu uroven' i osnovnyye napravleniya razvitiya gidroturbostroyeniya v Ukraine [The current level and main directions of development of hydroturbation in Ukraine]. *Problemy mashinostroyeniya*. 2010, vol. 13, no 1, pp. 11–18.
2. Veremeenko I. S. Polveka poiska i sozidaniya – itogi i perspektivy razvitiya otechestvennogo gidroturbostroyeniya [Half a century of search and creation – the results and prospects of development of the domestic hydro-turbine]. *Problemy Mashinostroyeniya*. 2003, vol. 6, no. 2, pp. 4–25.
3. Landau Yu. A. Osnovnye tendentsii razvitiya gidroenergetiki Ukrainy [The main trends in the development of hydropower in Ukraine]. *Nauchnye raboty*. Kharkov, 2014, vol. 53, iss. 40, pp. 82–86.
4. Sukhorebryy P. N. Raschet spiral'nykh kamer radial'no-osevykh obratimyykh gidromashin [Calculation of spiral chambers radial-axial reversible hydraulic machines]. *Bulletin of the National Technical University "KhPI". Series: Hydraulic machines and hydraulic units*. Kharkiv, NTU "KhPI" Publ., 2001, issue 129, part 1.1, pp. 79–89.
5. Nicolet C., Alligne S., Kawkabani B. Unstable operation of Francis Pump-Turbine at runaway: Rigid and elastic water column oscillation modes. *Journal of Fluid Machinery and Systems*. 2009, vol. 2, no. 4, pp. 324–333.
6. Topazh G. I. *Lopastnye gidromashiny i gidrodinamicheskie peredachi. Osnovy rabocheho protsessu gidroturbin* [Vane hydraulic

- machines and hydrodynamic transmission. Basics of the workflow hydroturbines]. Sankt-Peterburg, Politehn. Universitet. Publ., 2011. 154 p.
7. Rusanov A. V., Linnik A. V., Sukhorebryy P. N., Khorev O. N., Ryabov A. V. Matematicheskoe modelirovanie techeniya zhidkosti i analiz kharakteristik potoka v podvode gidroturbiny PL20 Kremenchugskoy GES [Mathematical modeling of fluid flow and analysis of flow characteristics in the supply of a PL20 hydroturbine of the Kremenchug hydroelectric station]. *Visnyk Nats. tekhn. un-ta "KhPI". Seriya: Enerhetychni i teplotekhnichni protsesy i ustakuvannya* [Bulletin of the National Technical University "KhPI". Series: Energy and heat engineering processes and equipment]. Kharkiv, NTU "KhPI" Publ., 2014, no. 1 (1044), pp. 41–48.
  8. Brekke H. *Hydraulic Turbines Design, Erection and Operation*. Endringsdato, Norway, 2000. 317 p.
  9. Rusanov A. V., Hnyesin V. I. *Naukovo-tekhnicni osnovy modelyuvannya i proektuvannya protochnykh chastyn enerhetychnykh turboustanovok* [Scientific and technical bases of modeling and designing of flowing parts of power turbo installations]. Kharkiv, Ipmash Publ., 2019. 386 p.
  10. Potetenko O. V., Krupa E. S. Kompleksnye eksperimental'nye issledovaniya turbulentnoy struktury potoka v protochnoy chasti vysokonapornoy radial'no-osevoy gidroturbiny [Comprehensive experimental studies of the turbulent flow structure in the flow part of a high-pressure radial-axial hydraulic turbine]. *Bulletin of the National Technical University "KhPI". Series: Hydraulic machines and hydraulic units*. Kharkiv, NTU "KhPI" Publ., 2016, no. 20 (1192), pp. 33–40.
  11. Linnik A. V., Ryabov A. V. Eksperimental'nyy stand PAO "Turboatom" dlya fizicheskogo modelirovaniya gidrodinamicheskikh protsessov v protochnykh chastyakh modeley povorotno-lopastnykh gidroturbin [Experimental stand of PJSC "Turboatom" for the physical modeling of hydrodynamic processes in the flow parts of the Kaplan turbine models]. *Problemy Mashinostroyeniya*. 2014, vol. 14, no. 3, pp. 11–18.
  12. Rusanov A. Designing and updating the flow part of axial and radial-axial turbines through mathematical modeling. *Central European Journal of engineering*. 2015, vol. 5, pp. 399–410.
  13. Masami Harano, Kiyohito Tani, Nomoto Satoru. Practical application of high-performance Francis-turbine runner fitted with splitter blades at Ontake and Shikurobegawa No. 3 power station of the Kansai electric power Co., inc. *Hitachi Review*. 2006, vol. 55, no. 3, pp. 109–113.
  14. Mironov K. A. Proektirovanie rabochikh koles radial'no-osevoy vysokonapornoy gidroturbiny na parametry GES Kameng [Design of impellers radial-axial high-pressure hydraulic turbine on the parameters of hydroelectric Kameng]. *Vestnik Nats. tekhn. un-ta "KhPI": sb. nauch. tr. Temat. vyp.: Tekhnologii v mashinostroyeni* [Bulletin of the National Technical University "KhPI": a collection of scientific papers. Thematic issue: Technologies in mechanical engineering]. Kharkov, NTU "KhPI" Publ., 2010, no. 24, pp. 69–76.
  15. Fridman L. I., Veremeenko I. S., Ust'ev A. D., Potetenko O. V. *Rabochee koleso radial'no-osevoy gidroturbiny* [Runner of radial-axial hydraulic turbine]. Patent USSR, no. 1188359, 1985.
  16. Potetenko O. V., Drankovskiy V. E., Krupa E. S., Vakhrusheva O. S. Sovershenstvovanie rabochikh protsessov gidroturbin s primeneniem novykh konstruktivnykh resheniy dlya razlichnykh diapazonov naporov [Improving hydraulic turbine workflows using new design solutions for various pressure ranges]. *Visnyk Nats. tekhn. un-ta "KhPI". Seriya: Enerhetychni i teplotekhnichni protsesy i ustakuvannya* [Bulletin of the National Technical University "KhPI". Series: Energy and heat engineering processes and equipment]. Kharkiv, NTU "KhPI" Publ., 2014, no. 1 (1044), pp. 49–57.
  17. Sokol E. I., Ishchenko G. I., Cherkasskiy A. Yu., Ishchenko M. G., Linnik A. V. Tekhnologicheskoye obespecheniye izgotovleniya gidravlicheskoy turbiny dlya Dnestrovskoy GAES [Technological support for the manufacture of a hydraulic turbine for the Dniester PSP]. *Visnyk Nats. tekhn. un-ta "KhPI". Seriya: Tekhnologii v mashinobuduvanni* [Bulletin of the National Technical University "KhPI". Series: Technology in mechanical engineering]. Kharkiv, NTU "KhPI" Publ., 2017, no. 26 (1248), pp. 5–13.
  18. Subbotin V. G., Levchenko Ye. V., Yefimenko V. N. Oborudovaniye OAO "Turboatom" dlya gidroelektrostantsiy Ukrainy: modernizatsiya, reabilitatsiya i perspektivy sozdaniya novykh tipov [Equipment of OJSC "Turboatom" for hydroelectric power plants of Ukraine: modernization, rehabilitation and prospects for the creation of new types]. *Gidroenergetika Ukrainy*. 2009, no. 2, pp. 33–43.
  19. Potetenko O. V., Krupa E. S., Drankovskiy V. E., Rezvaya K. S. Osobennosti rabocheho protsesa novykh tipov gorizontalnykh pryamotochnykh i vertikal'nykh radial'no-osevykh gidroturbin na vysokie napory [Features of the working process of new types of horizontal straight-through and vertical radial-axial hydraulic turbines for high heads]. *Visnyk Natsional'noho universytetu vodnoho hospodarstva ta pryrodokorystuvannya* [Bulletin of the National university of water and environmental engineering]. Rovno, 2015, issue 3 (71): Part 1. Tekhnichni nauky [Technical sciences], pp. 281–285.
  20. Robuk N. N., Melavtsov A. A., Fridman L. I., Ostashchenko A. V., Mishev Yu. N., Savin V. N., Potetenko O. V., German S. I. *Rabochee koleso radial'no-osevoy gidroturbiny* [Runner of radial-axial hydraulic turbine]. Patent USSR, no. 206422, 1967.

Received 16.09.2019

## Відомості про авторів / Сведения об авторах / About the Authors

**Мигущенко Руслан Павлович (Мигущенко Руслан Павлович, Migushchenko Ruslan)** – доктор технічних наук, професор, Національний технічний університет «Харківський політехнічний інститут», проректор з науково-педагогічної роботи; м. Харків, Україна; ORCID: <https://orcid.org/0000-0003-2523-595X>; e-mail: omsroot@kpi.kharkov.ua

**Потетенко Олег Васильович (Потетенко Олег Васильевич, Potetenko Oleg)** – кандидат технічних наук, доцент, Національний технічний університет «Харківський політехнічний інститут», професор кафедри «Гідравлічні машини ім. Г. Ф. Проскури»; м. Харків, Україна; ORCID: <https://orcid.org/0000-0002-3399-5580>; e-mail: potetenko.ov@gmail.com

**Гасюк Олександр Іванович (Гасюк Александр Иванович, Gasiyk Alexander)** – кандидат технічних наук, доцент, Національний технічний університет «Харківський політехнічний інститут», доцент кафедри «Гідравлічні машини ім. Г. Ф. Проскури»; м. Харків, Україна; ORCID: <https://orcid.org/0000-0001-6347-8501>; e-mail: galexom@gmail.com

**Крупа Євгеній Сергійович (Крупа Евгений Сергеевич, Krupa Evgeniy)** – кандидат технічних наук, Національний технічний університет «Харківський політехнічний інститут», доцент кафедри «Гідравлічні машини ім. Г. Ф. Проскури», м. Харків, Україна; ORCID: <https://orcid.org/0000-0002-2457-0097>; e-mail: zhekr@ukr.net