

N. FATIEIEVA, O. FATYEYEV, V. PONOMAROV

ADVANTAGES OF USING HYDRAULIC EQUIPMENT OF MODULAR MOUNTING IN THE MODERNIZATION OF MACHINE HYDROSYSTEMS

With each passing year, automation schemes that use hydraulics are becoming more and more complex. With the large number of hydraulic devices in the scheme, replacing threaded connections with other methods of mounting becomes very important. The analysis of building and mounting of hydraulic drives and hydraulic units on the example of metal-cutting machines, namely: round saw and turret lathe. The analysis shows that the optimal variant of pipeless mounting of hydraulic drives is mounting with the use of modular and butt hydraulic equipment. The main advantages of modular mounting are: reducing the number of pipelines and their connections; increasing drive rigidity, reducing noise; compactness, small size and weight; reducing labor costs and time for design and manufacture of the drive; convenience of operation, the ability to quickly reconfigure the drive, replace the failed unit without disassembly of the hydraulic drive; unification of mounting plates and hydraulic panels; increasing their seriality. In addition, with this type of mounting, there is always a constant distance between the individual devices and regulating bodies of different apparatuses that make up a typical element of a hydraulic system (its structural contour). This makes it possible to determine in advance the characteristics, properties and "behavior" not of individual hydraulic apparatuses included in the hydraulic system of the machine drive, but of groups of apparatuses that make up typical modular units. We have an opportunity to judge the characteristics of the hydraulic drive of the machine as a whole already at the stage of its design by predetermined characteristics of typical elements (modular units) included in the hydraulic system of the machine, which will significantly reduce the time for designing, debugging and launching the drive in production. The group of metalworking equipment, in which the hydraulic drive on the basis of modular and butt hydraulic equipment is easily performed, includes: turning group machines; drilling and boring machines; grinding group machines; broaching machines; cutting machines, milling machines and other special machines. Justified selection of the nomenclature of normalized hydrostations, modular and butt hydraulic apparatuses and other unified elements can solve the problem of creating up to 70–75 % of the manufactured hydraulic drives completely based on unified units.

Keywords: hydraulic drive, machine hydrosystems, modular mounting, butt mounting, structural contour, hydraulic panel, modular unit.

Н. М. ФАТЄЄВА, О. М. ФАТЄЄВ, В. А. ПОНОМАРЬОВ

ПЕРЕВАГИ ВИКОРИСТАННЯ ГІДРОАПАРАТУРИ МОДУЛЬНОГО МОНТАЖУ ПРИ МОДЕРНІЗАЦІЇ ВЕРСТАТНИХ ГІДРОСИСТЕМ

З кожним роком схеми автоматизації, що реалізуються, із застосуванням гідравліки, стають все складніше і складніше. При великій кількості гідравлічних апаратів у схемі заміна різьбових з'єднань на інші способи монтажу стає дуже актуальною. Проведено аналіз побудови і монтажу гідравлічних приводів і гідроагрегатів на прикладі металорізальних верстатів, а саме: круглопильного та токарно-револьверного. Аналіз показує, що оптимальним варіантом безтрубного монтажу гідроприводів є монтаж з використанням модульної і стикової гідроапаратури. Основними перевагами модульного монтажу є: скорочення кількості трубопроводів і їх з'єднань; підвищення жорсткості приводу, зниження шуму; компактність, малі габарити і маса; зниження витрат праці і часу на розробку і виготовлення приводу; зручність експлуатації, можливість швидкого переконструювання приводу, заміни вийшовшого з ладу апарату без розбирання гідроприводу; уніфікація монтажних плит і гідропанелей, збільшення їх серійності. Крім того, при зазначеному виді монтажу завжди дотримується сталість відстані між окремими апаратами і регулюючими органами різних апаратів, які входять в модульний блок і складають типовий елемент гідросистеми (її структурний контур). Це дає можливість заздалегідь визначити характеристики, властивості і «поведінку» вже не окремих гідроапаратів, що входять в гідросистему приводу машини, а груп апаратів, що становлять типові модульні блоки. Є можливість за заздалегідь визначеними характеристиками типових елементів (модульних блоків), що входять в гідросистему машини, судити про характеристики гідроприводу машини в цілому вже на стадії його проектування, що дозволяє значно скоротити час на проектування, налагодження і запуск приводу в виробництво. До групи металообробного обладнання, в якій легко виконується гідравлічний привід на базі модульної і стикової гідроапаратури відносяться: верстати токарної групи; верстати свердлильні й розточувальні; верстати шліфувальної групи; протяжні верстати; верстати відрізні, фрезерні та інші спеціальні верстати. Обґрунтований вибір номенклатури нормалізованих гідростанцій, модульної та стикової гідроапаратури і інших уніфікованих елементів може вирішити задачу створення на базі уніфікованих вузлів до 70–75 % випущених гідроприводів.

Ключові слова: гідропривод, верстатні гідросистеми, модульний монтаж, стиковий монтаж, структурний контур, гідропанель, модульний блок.

Introduction. At present, a considerable part of hydraulic equipment is produced with butt connections, mostly with unified international connection dimensions. Unification of connection and mounting holes of joint planes provides unhindered replacement of devices, simplifies the conditions of operation and repair of equipment, as well as creates a wide range of opportunities for export. Significant experience has been accumulated in its application and operation [1–5]. The use of butt equipment has the following disadvantages: the hydropanel body on which the equipment is mounted is complicated; metal consumption is increased; it is difficult to detect and eliminate the error made during the design or manufacture of the panel body; the unsuitability of the panel bodies for use in upgrading the cycle of the hydroficated machine; the impossibility of unifying the panel bodies.

The result of further development of hydraulic equipment of butt design is modular equipment [6, 7].

Hydraulic devices of modular design regardless of their functional purpose have two joint planes with the same coordinates of connection holes (mounting holes and channels of flow inlet, drain and outlet to the executive hydromechanism). Therefore, it is possible to assemble individual parts and elements of hydraulic schemes from the devices of modular design by installing the devices one on one in the form of a package, the closing elements of which are directional valves or blanking plates. By connecting the packages installed on the mounting plates with each other, we get a hydropanel [2, 8–10].

Hydraulic equipment of modular design not only has all the advantages of conventional hydraulic equipment of butt design, but also allows you to make the hydraulic drive light, compact, easy to install and operate without connecting pipes.

It should be noted, that for hydraulic systems with high and ultrahigh pressure and high flow rates of working fluid, another direction in the construction of hydraulic

drives with pipeless mounting method is the creation of valve hydraulic equipment built into the holes, which is based on a check valve operated hydraulically or electrohydraulically [11].

Analysis of the state of the issue. It is known, that the basis of hydraulic equipment of modern metal-cutting machines, presses and other machines are hydraulic systems of reciprocating motion (or rotational), which in practice there are a large number of design variants.

However, despite the great variety of hydraulic systems, their basic and design solutions have much in common [2, 12]. This applies first and foremost to the hydraulic systems of machine tools for specific applications. For example, the hydraulic systems of internal grinding machines operating on a semi-automatic cycle have much in common in design. Also similar are the hydraulic systems of external cylindrical grinding machines, aggregate machines, semi-automatic lathes, discrete and program-controlled machines.

Thus, careful study, analysis and classification of hydraulic drives of machine tools, presses and other hydroficated machines allow to identify and group individual typical elements of schemes (structural contours), common to drives of various machines regardless of their intended purpose. This is the basis for creating individual unified functional blocks that implement typical structural contours of hydraulic systems, based on hydraulic equipment of modular and butt design, determining their needs for the industry and establishing serial production of modular blocks and unified panels based on them, which in turn allows you to perform hydraulic machinery drive by aggregation method [6].

Fig. 1 shows an example of a typical hydraulic system structure for controlling the duty cycle of a

machine's hydraulic actuator (direction and speed in both directions, locking at the end of the cylinder stroke) [2]. The modular unit for controlling the movement and speed of a hydraulic cylinder is shown as an example of Rexroth hydraulic units [13].

As the analysis shows, hydraulic panels of some groups of machines are easily performed completely on modular hydraulic equipment (hydraulic panels of gear-working machines, milling machines, slotting machines, some lathe semiautomatic machines). In this case, units of modular equipment are installed on single or multi-seat mounting plates (depending on the complexity of the hydraulic system).

Fig. 2–4 show examples of typical hydraulic schemes structure contours, the implementation of which is conveniently carried out with the help of modular hydraulic equipment. [6, 13, 14].

The same contours can also be made on the basis of butt equipment, but then the number of mounting plates will be determined by the number of apparatuses included in the structural contour of the hydromechanism of the machine.

To build a hydraulic scheme of a machine drive using modular elements it is necessary to have a certain practical skill. It is recommended to first bring the already existing conventional hydraulic scheme of the drive to a form suitable for modular mounting.

Main part. As an example, consider the hydraulic drive scheme of a round saw machine (Fig. 5). The machine hydraulic drive consists of hydraulic tank 1, two executive hydraulic cylinders 6 and 7, fed from one pump 2, control and regulating 3, 5, 9 and distributing 4, 8 hydraulic equipment. The speeds of the executing hydraulic cylinder 6 are regulated by the flow control valves 5 as it moves in both directions.

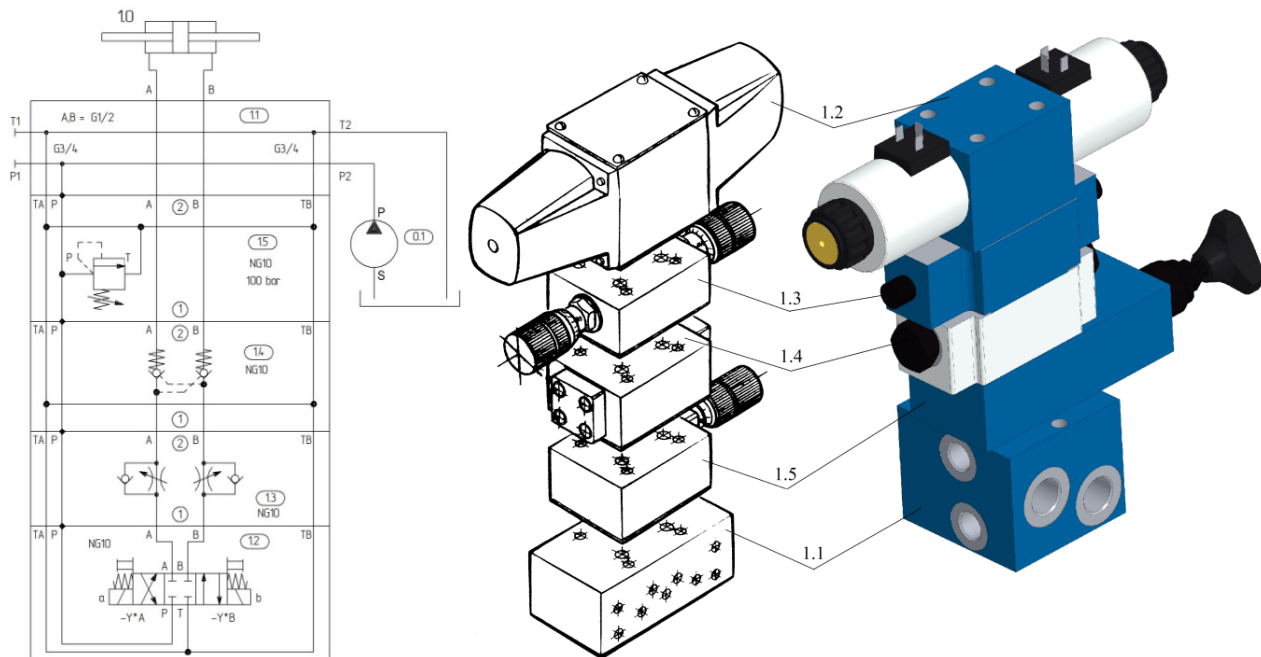

Fig. 1. Functional modular unit to control movement and speed of hydraulic cylinder:

0.1 – pump; 1.0 – hydraulic cylinder; 1.1 – mounting plate; 1.2 – directional valve; 1.3 – twin throttle check valve; 1.4 – check valve, pilot operated; 1.5 – pressure relief valve

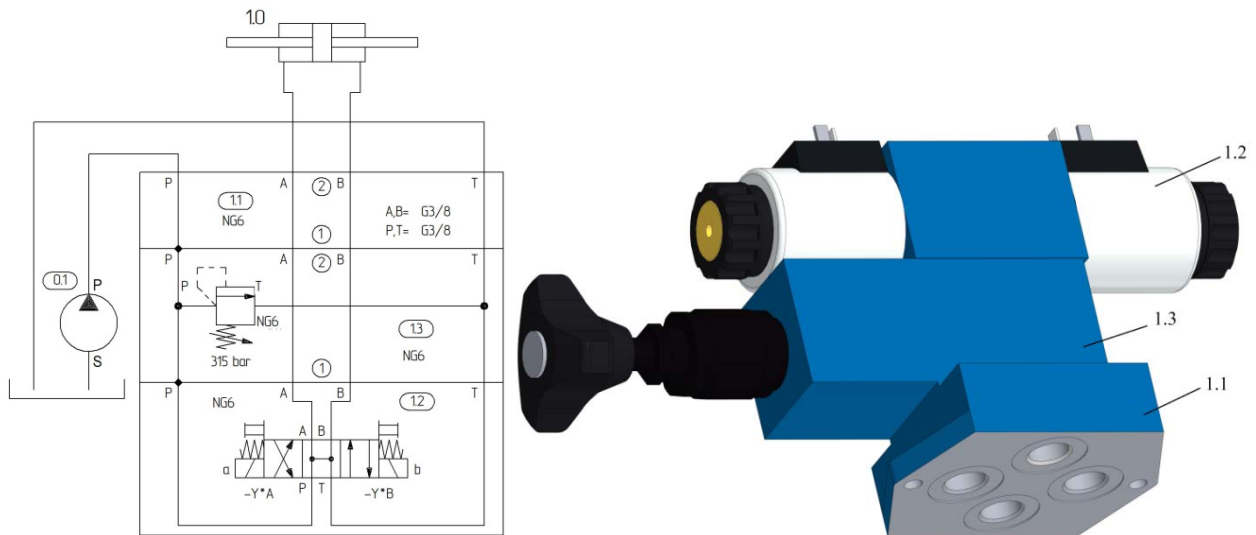

Fig. 2. Modular unit for hydraulic cylinder movement control:

0.1 – pump; 1.0 – hydraulic cylinder; 1.1 – mounting plate; 1.2 – directional valve; 1.3 – pressure relief valve

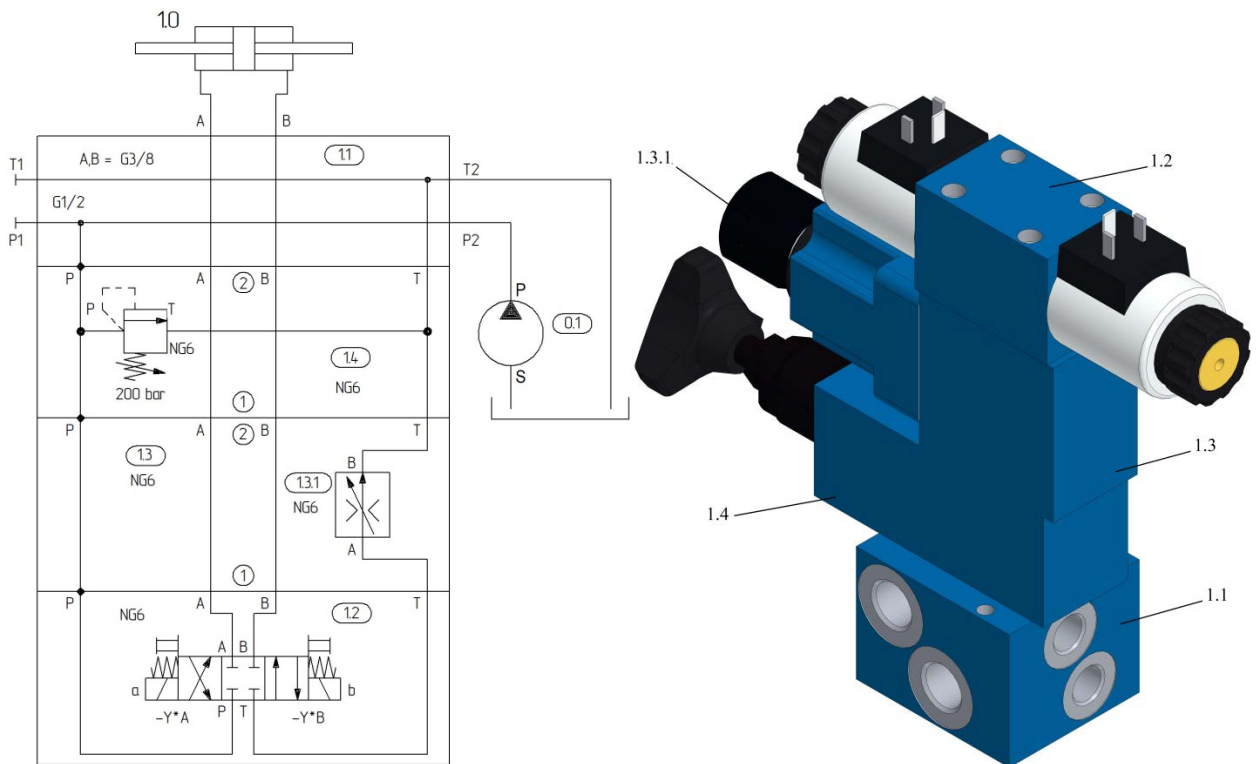

Fig. 3. Modular unit to control movement and speed (the same in both directions) of the hydraulic cylinder:

0.1 – pump; 1.0 – hydraulic cylinder; 1.1 – mounting plate; 1.2 – directional valve; 1.3 – mounting plate; 1.3.1 – flow control valve; 1.4 – pressure relief valve

Hydraulic cylinder 7 uses working fluid at a pressure lower than the pressure in the main line supplying hydraulic cylinder 6, which is ensured by the installation of the pressure reducing valve 9. Analyzing the hydraulic scheme, we distinguish two structural contours that implement the work cycle of the executing hydraulic cylinders of the machine.

The first structural contour implements the operating cycle of the executive hydraulic cylinder 6 and includes the pressure relief valve 3, directional valve 4, flow control valves 5.

The second contour controls the movement of the

hydraulic cylinder 7 and includes the pressure reducing valve 9 and directional valve 8. The hydropanel is easy to execute using a two-seat mounting plate and hydraulic equipment in a modular design (Fig. 5).

The hydraulic scheme of the machine drive using a two-seat mounting plate and hardware in the modular design is shown in Fig. 6.

An example of a hydraulic drive based on modular elements is also the drive of a turret lathe.

Fig. 7 shows the available typical hydraulic scheme of the machine, it is built with the use of hydraulic devices of pipe and butt design.

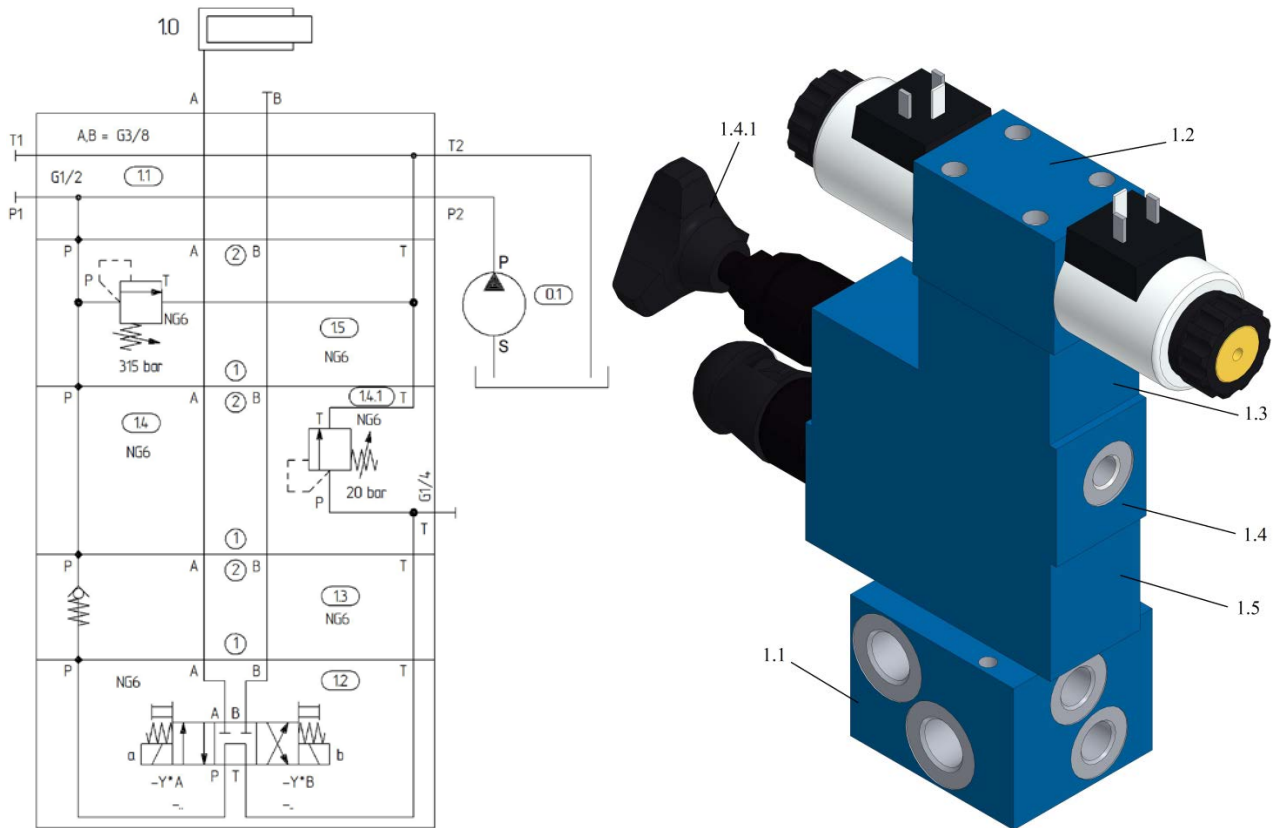

Fig. 4. Modular block for control of hydraulic cylinder of loader, elevator and other mechanisms:
 0.1 – pump; 1.0 – hydraulic cylinder; 1.1 – mounting plate; 1.2 – directional valve; 1.3 – check valve; 1.4 – mounting plate;
 1.4.1 – pressure valve; 1.5 – pressure relief valve

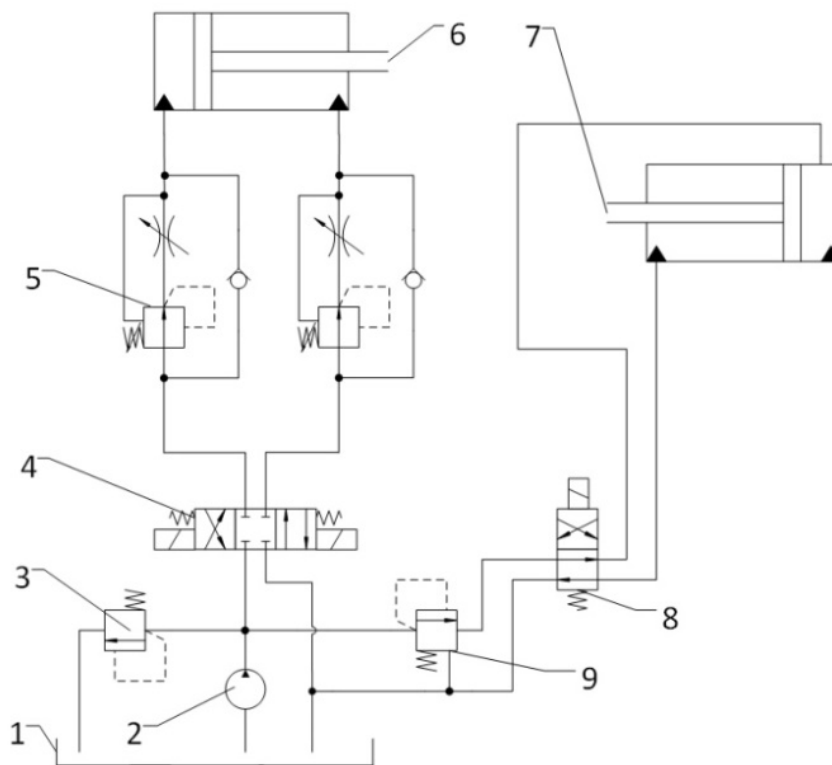

Fig. 5. Hydraulic scheme of the round saw machine drive:
 1 – tank; 2 – pump; 3 – pressure relief valve; 4, 8 – directional valves; 5 – flow control valves; 6, 7 – hydraulic cylinders; 9 – pressure reducing valve

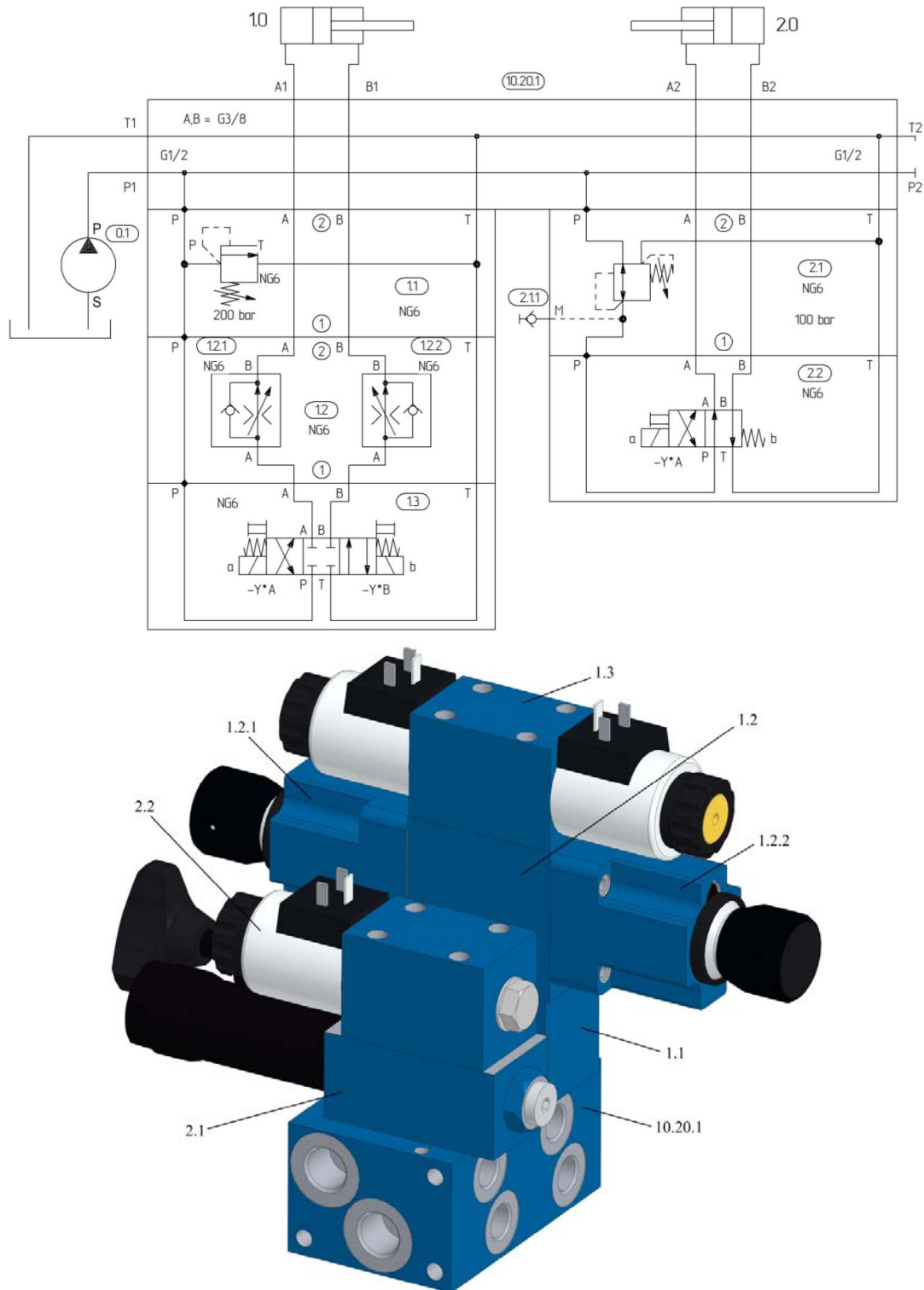

Fig. 6. Hydraulic scheme of round saw machine drive, made on the basis of modular equipment and two-seat mounting plate:
 0.1 – pump; 1.0, 2.0 – hydraulic cylinders; 10.20.1 – mounting plate; 1.1 – pressure relief valve; 1.2 – mounting plate;
 1.2.1, 1.2.2 – flow control valves; 1.3, 2.2 – directional valves; 2.1 – pressure reducing valve

The hydraulic scheme of the machine provides main and auxiliary movements of the executive elements: clamping of blanks with the specified force; clamping of the turret, its rotation when changing positions; working and auxiliary movements of the cutting caliper; operation of the device for automatic unloading of parts; pressure control in the lines of discharge and clamping.

The hydroscheme consists of:

- discharge line including: pump P, filters F1 and F2, pressure relief valve PV2 and check valve CV;
- the workpiece clamping line, including: pressure reducing valve PRV, directional valve D1, pressure sequence valve PV1, hydraulic cylinders of clamping C1 and C2;
- cutting caliper line, which includes: directional valve D3, flow control valve A2, hydraulic cylinder C3;

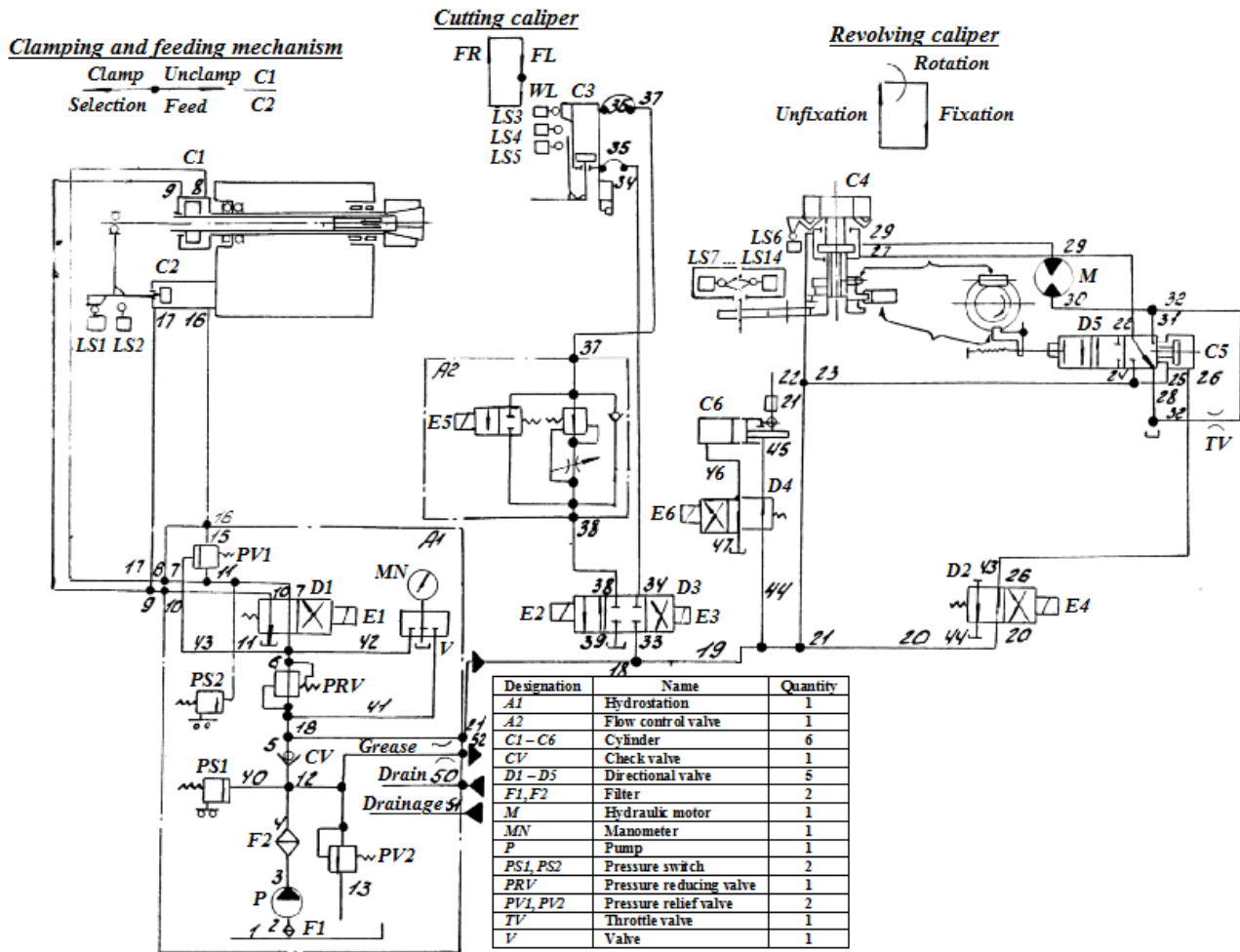

Fig. 7. Hydraulic scheme of the turret lathe drive

- control line of the turret caliper, including: hydraulic directional valves D2 and D5, hydraulic motor M, hydraulic cylinders C4 and C5;

- unloading device line, which includes hydraulic directional valve D4, hydraulic cylinder C6.

The pressure in the discharge line is set by the pressure relief valve PV2.

Fig. 8 shows the hydraulic scheme of a turret lathe drive, developed with the use of hydraulic units of modular and butt design.

The hydroscheme consists of:

- discharge line including: pump 0.1, filter, pressure relief valve 1.1 modular design;

- the workpiece clamping line, which includes: check valve 1.2 modular design, pressure reducing valve 1.3 modular design, pressure relief valve 1.4 modular design, hydraulic directional valve 1.5 butt design, hydraulic clamping cylinders 1.0.1 and 1.0.2;

- control line of the turret caliper which includes: check valve 2.1 modular design, pressure relief valve 2.2 modular design, throttle with check valve 2.3 modular design, check valve 2.4 modular design, hydraulic directional valve 2.5 butt design, hydraulic motor 2.0;

- cutting caliper line, which includes: check valve 3.1 modular design, flow control valve 3.2 modular design, hydraulic directional valve 3.3 butt design, hydraulic cylinder 3.0;

- unloading device line, which includes: check valve 4.1 modular design, throttle with check valve 4.2 modular design, hydraulic directional valve 4.3 butt design, hydraulic cylinder 4.0.

The pressure in the discharge line is set by the pressure relief valve 1.1.

Comparison shows that the hydraulic drive of a turret lathe made on the basis of modular and butt hydraulic equipment has two times less pipelines, end and intermediate connections in relation to the serial one. The weight of the hydraulic panel is 2,5 times less than that of a serial hydraulic panel, and labor intensity of manufacturing is 3,5 times less. The noise of the drive was reduced by 1-2 dB.

Results of the analysis. The main advantages of modular mounting are: reducing the number of pipelines and their connections; increasing drive rigidity, reducing noise; compactness, small size and weight; reducing labor costs and time for the design and manufacture of the drive; usability, the ability to quickly reconfiguration drive, replace a failed unit without disassembly of the hydraulic drive; reducing losses by reducing the path of flow of working fluid in the system and the number of local resistances; improving the appearance of the hydraulic drive; unification of mounting plates and hydropanels; increasing their seriality.

In addition, with this type of mounting, there is

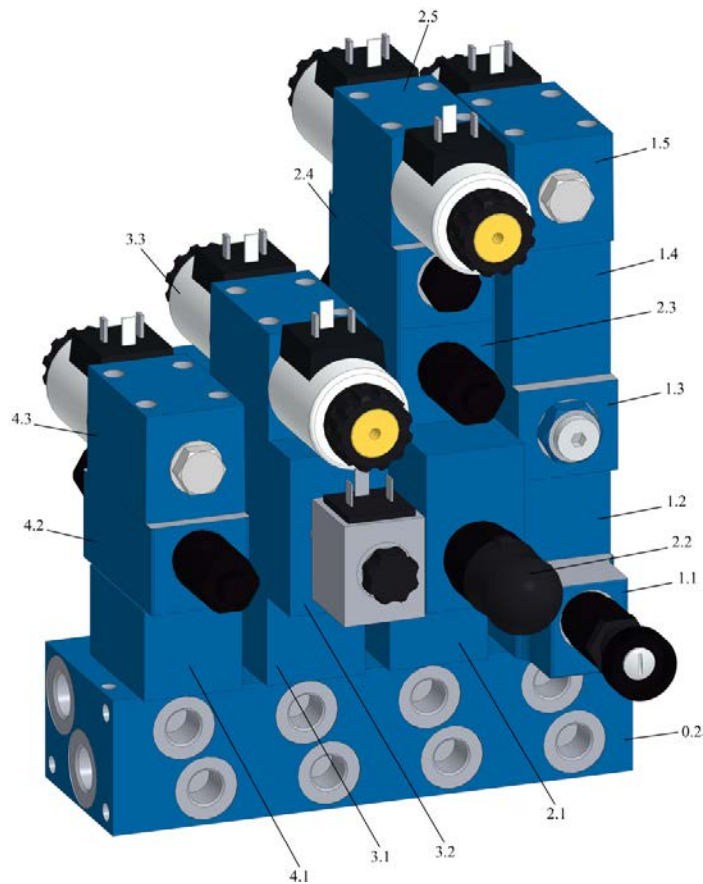
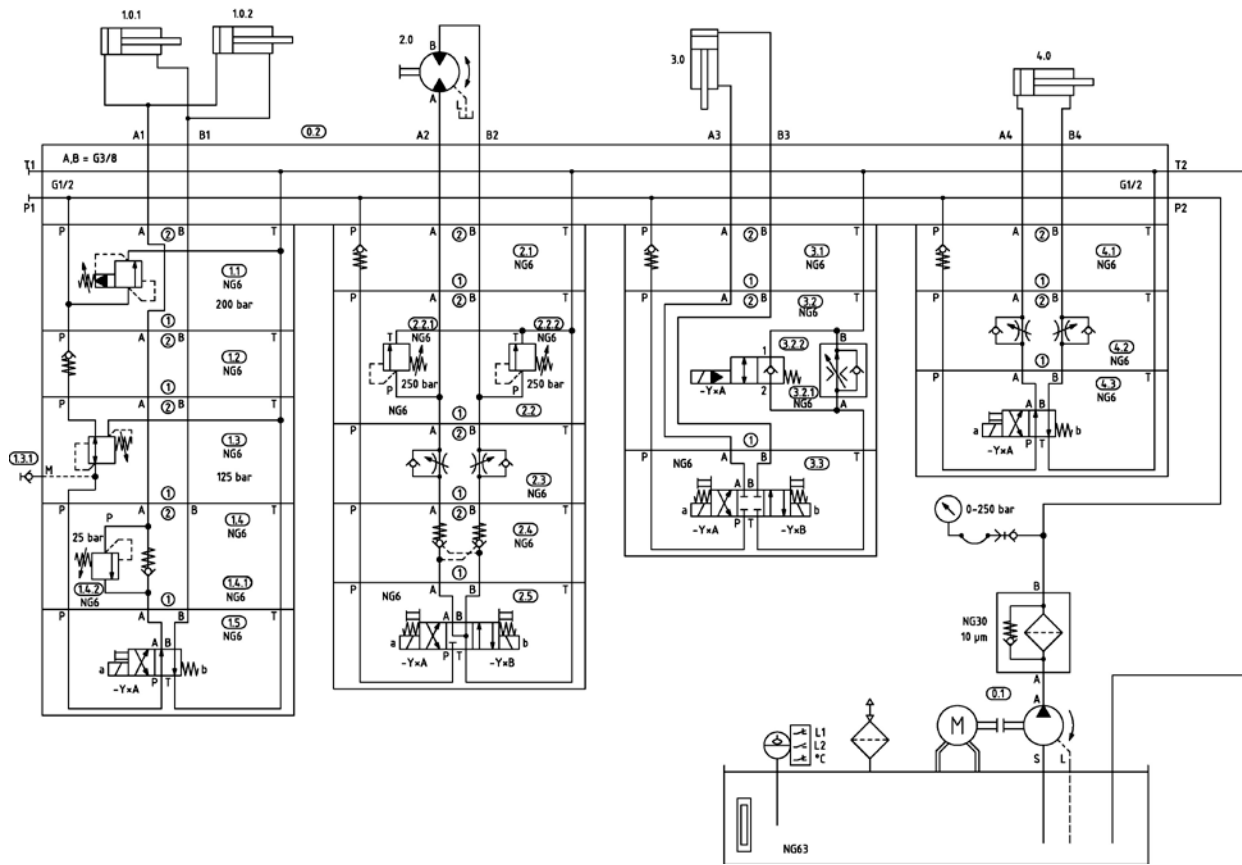

Fig. 8. Hydraulic scheme of the turret lathe drive, made with modular equipment:
 0.1 – pump; 0.2 – mounting plate; 1.0.1, 1.0.2, 3.0, 4.0 – hydraulic cylinders; 1.1, 1.4, 2.2 – pressure relief valves;
 1.2, 2.1, 2.4, 3.1, 4.1 – check valves; 1.3 – pressure reducing valve; 1.5, 2.5, 3.3, 4.3 – directional valves; 2.0 – hydraulic motor;
 2.3, 4.2 – throttles with check valves

always a constant distance between the individual devices and regulating bodies of different apparatuses that make up a typical element of a hydraulic system (its structural contour). This makes it possible to determine in advance the characteristics, properties and "behavior" not of individual hydraulic apparatuses included in the hydraulic system of the machine drive, but of groups of apparatuses that make up typical modular units. We have an opportunity to judge the characteristics of the hydraulic drive of the machine as a whole already at the stage of its design by predetermined characteristics of typical elements (modular units) included in the hydraulic system of the machine, which will significantly reduce the time for designing, debugging and launching the drive in production.

The conducted analysis of building and mounting of hydraulic drives and hydraulic units, tendencies of development of hydraulic schemes of hydraulic drives of machines shows that the optimal variant of the pipeless mounting is mounting with the use of modular and butt-type hydraulic apparatuses. The execution of hydraulic drives on the basis of only one type of hydraulic apparatus (e.g., modular) is not always possible and justified.

Dimensions of the devices of modular design are determined by the size of the butt plane of the directional valve, which is usually the final link in the block of modular apparatus (see Fig. 1), so the conditional passage of the devices of modular design is limited to $D_c = 6\text{--}16$ mm, since the modular devices of larger conditional passages in size and weight are several times larger than the units of butt design.

In addition, the functionality of modular apparatuses does not cover all variants and designs of butt-type apparatuses, which is explained by dimensional restrictions. In units of modular apparatuses at high pressure, butt openings and depressurization are possible. Therefore, modular apparatuses are limited in pressure up to 4552 psi [6, 14].

Therefore, it is rational to use in each particular hydraulic drive those types of apparatuses or combinations of different types, which allow for a given drive to realize the optimal cycle of operation of a hydroficated machine in all major technical parameters, in other words, those apparatuses, the advantages of which would be decisive for a given drive.

Depending on the selected hydraulic apparatuses it is necessary to develop a hydraulic scheme of the drive in a form suitable for the use of modular elements, to determine the number of mounting, intermediate and sealing plates, the sequence of their connection and the overall dimension of the panels.

Conclusions. Thus, the currently producing hydraulic stations with tank capacity from 10 to 1000 l and pumps with capacity from 3 to 250 l/min at pressure up to 4552 psi, control and distributive hydraulic apparatuses with international connection sizes, complexes of modular hydraulic apparatuses with conditional passages 6, 10 and 16 mm can solve the problem of creation and modernization of hydraulic drives on the basis of unified elements, using progressive modern methods of their building and mounting. This will reduce

labor input in design and manufacturing of hydraulic drives by 30–40 % with a sharp reduction in terms of creation and implementation of new machines and equipment, reduce costs for maintenance and repair of hydraulic drives, increase their reliability.

The group of metalworking equipment, in which the hydraulic drive on the basis of modular and butt hydraulic equipment is easily performed, includes: turning group machines; drilling and boring machines; grinding group machines; broaching machines; cutting machines, milling machines and other special machines.

Justified selection of the nomenclature of normalized hydrostations, modular and butt hydraulic apparatuses and other unified elements can solve the problem of creating up to 70–75 % of the manufactured hydraulic drives completely based on unified units.

References

1. Волоцкий В. М. *Гидравлические приводы машин и их оборудование*. Харьков: Гидроэлект, 1995. 155 с.
2. Свешников В. К. *Станочные гидроприводы*. Машиностроение, 2008. 640 с.
3. Фінкельштейн З. Л., Андренко П. М., Дмитрієнко О. В. *Експлуатація, обслуговування та надійність гідравлічних машин і гідроприводів: навч. посіб.* Харків: НТУ «ХПІ», 2014. 308 с.
4. Буренников Ю. А., Немировський І. А., Козлов Л. Г. *Гідравліка, гідро- та пневмоприводи*. Вінниця: ВНТУ, 2013. 273 с.
5. Аврун Г. А., Кириченко І. Г., Самородов В. Б. *Гідравлічне обладнання будівельних та дорожніх машин*. Харків: ХНАДУ, 2016. 438 с.
6. Наумчук Ф. А., Оксененко А. Я., Филатов Р. А., Набока И. П., Уманская Т. А. *Модульный монтаж гидравлических приводов*. НИИмаш, 1979. 39 с.
7. Пинчук В. В. *Расчет и конструирование агрегатно-модульных гидроблоков управления гидроприводов технологического оборудования: автореф. дис. на соискание учен. степени д-ра техн. наук: спец. 05.02.02 «Машиноведение, системы приводов и детали машин»*. Минск, 2016. 41 с.
8. Экнер Х., Фрейтаг Р., Гайс Х., Ланг Р., Опольцер Й., Шваб П., Зумпф Е., Остендорф У., Райк М. *Гидропривод. Основы и компоненты. Том 1*. Эрбах: Бош Рекрот АГ Сервис Автоматизация Дидактика, 2003. 323 с.
9. *Типы монтажа гидроаппаратуры*. URL: <http://for-engineer.info/hydraulics/typy-montazha-gidroapparatury.html> (дата обращения: 02.08.2022).
10. *Аппараты модульного монтажа (применение и монтаж)*. URL: <https://hydraulic24.ru/apparatu-modulnogo-montazha-primeneniye-i-montazh/> (дата обращения: 04.08.2022).
11. Савченко О. Я., Єлізаров С. П., Кишковский В. О. Про нові напрямки в технології виготовлення гідроапаратури. *Аграрний вісник Причорномор'я: зб. наук. пр.* Одеса, 2012. Вип. 63: Технічні науки. С. 81–86.
12. *Металлорежущие станки*. URL: <https://www.metalstanki.com.ua> (дата обращения: 02.08.2022).
13. *Bosch Rexroth Configuration*. URL: https://www.boschrexroth.com/ics/Modules/Configuration/?Modelcode=HSR&p=p770880&Configurator=ReihenplattenHSR&CheckPreviousSelection=Grundplatte:%7B_::%7BR1G_RP_NOMINAL_SIZE=6%7D%7D&cat=Industrial-Hydraulics-Catalog&pi=4900CE67-A5CA-F4C2-0A19CD21FE13719B_IC_S_8801&scenario=portal&InitConfiguration=1&o=Desktop (дата звернення: 04.08.2022).
14. *Каталог гідравлічного обладнання*. URL: <https://motorimpex.ua/ua/catalog/> (дата звернення: 05.08.2022).

References (transliterated)

1. Volotskiy V. M. *Gidravlicheskie privody mashin i ikh oborudovanie* [Hydraulic machine drives and their equipment]. Kharkov, Gidroeleks Publ, 1995. 155 p.
2. Sveshnikov V. K. *Stanochnye gidroprivody* [Machine hydraulic drives]. Mashinostroenie Publ, 2008. 640 p.

3. Finkel'shteyn Z. L., Andrenko P. M., Dmytriyenko O. V. *Ekspluatatsiya, obsluhovuvannya ta nadiynist' hidravlichnykh mashyn i hidropriyvody* [Operation, maintenance and reliability of hydraulic machines and hydraulic drives]. Kharkiv, NTU "KhPI" Publ., 2014. 308 p.
4. Buryennikov Yu. A., Nemyrovskyy I. A., Kozlov L. H. *Hidravlika, hidro- ta pnevmopriyvody* [Hydraulics, hydraulic and pneumatic actuators]. Vinnitsa, VNTU Publ., 2013. 273 p.
5. Avrunin H. A., Kyrychenko I. H., Samorodov V. B. *Hidravlichne obladnannya budivelnnykh ta dorozhnykh mashyn* [Hydraulic equipment for construction and road vehicles]. Kharkiv, KhNADU Publ., 2016. 438 p.
6. Naumchuk F. A., Oksenenko A. Ya., Filatov R. A., Naboka I. P., Umanskaya T. A. *Modul'nyy montazh gidravlicheskiykh privodov* [Modular mounting of hydraulic drives.]. NIImash Publ., 1979. 39 p.
7. Pinchuk V. V. *Raschet i konstruirovaniye agregatno-modul'nykh gidroblokov upravleniya gidroprivodov tekhnologicheskogo oborudovaniya: avtoref. dis. na soiskanie uchen. stepeni d-ra tekhn. nauk: spets. 05.02.02 "Mashinovedeniye, sistemy privodov i detali mashin"* [Design and calculation of modular hydraulic control units in fluid drives of processing equipment. Abstract of a thesis dr. eng. sci. diss. 05.02.02 "Mechanical engineering, drive systems and machine parts"]. Minsk, 2016. 41 p.
8. Eksner Kh., Freytag R., Gays Kh., Lang R., Oppol'tser Y., Shvab P., Zumpf E., Ostendorff U., Rayk M. *Gidroprivod. Osnovy i komponenty. Tom 1* [Hydraulic Drive. Fundamentals and Components. Volume 1]. Erbach, Bosch Rexroth AG Servis Avtomatizatsiya Didaktika Publ., 2003. 323 p.
9. *Tipy montazha gidroapparatury* [Types of mounting of hydraulic apparatus]. Available at: <http://for-engineer.info/hydraulics/typy-montazha-gidroapparatury.html> (accessed 02.08.2022).
10. *Apparaty modul'nogo montazha (primeneniye i montazh)* [Modular mounting apparatus (application and mounting)]. Available at: <https://hydraulic24.ru/apparaty-modul'nogo-montazha-primeneniye-i-montazh/> (accessed 04.08.2022).
11. Savchenko O. Ya., Yelizarov S. P., Kyshkovskyy V. O. Pro novi napryamky v tekhnolohiyakh vyhotovlennyya hidroapparatury [About tendencies in technological solutions when manufacturing details]. *Ahrarnyy visnyk Prychornomor'ya: zb. nauk. pr.* [Agrarian Bulletin of the Black Sea Region: a collection of scientific papers]. Odesa, 2012, issue 63: Tekhnichni nauky [Technical sciences], pp. 81–86.
12. *Metallovezhushchie stanki* [Metal cutting machines]. Available at: <https://www.metalstanki.com.ua> (accessed 02.08.2022).
13. *Bosch Rexroth Configuration*. Available at: https://www.boschrexroth.com/ics/Modules/Configuration/?Modelcode=HSR&p=p770880&Configurator=ReihenplattenHSR&CheckPreviousSelection=Grundplatte:%7B_:%7BR1G_RP_NOMINAL_SIZE=6%7D%7D&cat=Industrial-Hydraulics-Catalog&pi=4900CE67-A5CA-F4C2-0A19CD21FE13719B_IC_S_8801&scenario=portal&InitConfiguration=1&o=Desktop (accessed 04.08.2022).
14. *Kataloh hidravlichnoho obladnannya* [Hydraulic Equipment Catalogue]. Available at: <https://motorimpex.ua/ua/catalog/> (accessed 05.08.2022).

Received 24.08.2022

Відомості про авторів / About the Authors

Фатеева Надія Миколаївна (Fatieieva Nadiia) – кандидат технічних наук, доцент, Національний технічний університет «Харківський політехнічний інститут», доцент кафедри «Гідравлічні машини ім. Г. Ф. Проскури»; м. Харків, Україна; ORCID: <https://orcid.org/0000-0001-6955-5301>; e-mail: nadin_yak@ukr.net

Фатеев Олександр Миколайович (Fatyeyev Oleksandr) – кандидат технічних наук, Національний технічний університет «Харківський політехнічний інститут», доцент кафедри «Гідравлічні машини ім. Г. Ф. Проскури»; м. Харків, Україна; ORCID: <https://orcid.org/0000-0002-9212-4507>; e-mail: fatyan1@ukr.net

Пonomарьов Владислав Анатолійович (Ponomarov Vladyslav) – Національний технічний університет «Харківський політехнічний інститут», аспірант кафедри «Гідравлічні машини ім. Г. Ф. Проскури»; м. Харків, Україна; ORCID: <https://orcid.org/0000-0001-8742-5615>; e-mail: ponomaridze1@gmail.com